

J-C Health Care Ltd.

מאי 2014

רופא/ה נכבד/ה
רוקח/ת נכבד/ת

ברצוננו להביא לידיעתכם את העדכונים בעלון לרופא ועלון לצרכן של התכשיר :

Risperdal Consta

השינויים מסומנים בעלונים המצורפים כאשר הטקסט המודגש באדום הוסף לעלון ואילו הטקסט המחוק בכחול נגרע ממנו.

העלונים מפורסמים במלואם באתר משרד הבריאות. כמו כן ניתן לקבל את העלונים המודפסים בפניה אלינו לטלפון 09-9591111 .

להלן העדכונים.

בברכה,

ליליאנה בלטר
רוקחת ממונה

עלון לצרכן לפי תקנות הרוקחים (תכשירים) התשמ"ו-1986**התכשיר נמכר עם מרשם רופא בלבד**

שם התכשיר וצורתו ריספרדל קונסטטה,

תרחיף בשחרור ממושך להזרקה תוך שרירית

הרכב החומר הפעיל וכמותו:

ריספרדל קונסטטה 25 מ"ג מכיל: Risperidone 25mg/vial ריספרידון 25 מ"ג/ג'ויאל

ריספרדל קונסטטה 37.5 מ"ג מכיל: Risperidone 37.5mg/vial ריספרידון 37.5 מ"ג/ג'ויאל

ריספרדל קונסטטה 50 מ"ג מכיל: Risperidone 50mg/vial ריספרידון 50 מ"ג/ג'ויאל

רכיבים בלתי פעילים ואלרגניים בתכשיר – ראה בסעיף 6

קרא בעיון את העלון עד סופו בטרם תשתמש בתרופה. עלון זה מכיל מידע תמציתי על התרופה. אם יש לך שאלות נוספות, פנה אל הרופא או אל הרוקח.

תרופה זו נרשמה לטיפול עבורך. אל תעביר אותה לאחרים. היא עלולה להזיק להם אפילו אם נראה לך כי מצבם הרפואי דומה

ריספרדל קונסטטה לא נבדק בניסויים קליניים בילדים ומתבגרים מתחת לגיל 18.

למה מיועדת התרופה?

לטיפול בסכיזופרניה, בהפרעות סכיזואפקטיביות ובהפרעה דו קוטבית

קבוצה תרפויטית: אנטיפסיכוטיים אטיפיים

לפני שימוש בתרופה**אין להשתמש בתכשיר אם:**

אין להשתמש אם ידועה רגישות (אלרגיה) לחומר הפעיל או לכל אחד מהמרכיבים הנוספים אשר מכילה התרופה (ראה בסעיף 6). רגישות יכולה להתבטא למשל בפריחה, גרד, קוצר נשימה או פנים נפוחות. אם אחת מתופעות אלה התרחשה, יש לגשת לרופא.

אזהרות מיוחדות הנוגעות לשימוש בתרופה:

- מחקרים בחולים קשישים הסובלים מדמנציה הראו שלקחת ריספרדל לכשעצמו או עם פורוסמיד קשורה בשכיחות גבוהה יותר של מקרי מוות. יש לומר לרופא אם הנך נוטל/ת פורוסמיד, תרופה לטיפול בלחץ דם גבוה, לבעיות מסוימות בלב או לבצקות בגוף עקב הצטברות נוזלים.
- בחולים קשישים הסובלים מדמנציה, נראו מקרי שינוי פתאומי במצב המנטלי או חולשה פתאומית או תחושת נימול של הפנים, הזרועות, או הרגליים ובייחוד בצד אחד של הגוף או מקרי דיבור לא ברור. אם אחד מאלה קרה ואפילו לפרק זמן קצר יש לפנות לעזרה רפואית מיד.
- אם מעולם לא נטלת ריספרדל בכל צורת מינון אחרת, יש להתחיל בריספרדל הנלקח דרך הפה לפני התחלת הטיפול בריספרדל קונסטטה.
- ריספרדל עלול לגרום לעלייה במשקל, נסה/י לאכול במתינות.
- במהלך שימוש ממושך, ריספרדל קונסטטה עלול לגרום לעויותות לא רצויות בפנים. במידה ותופעה זאת מתרחשת, יש לפנות לרופא
- לעיתים נדירות, מצב של בלבול, ירידה בהכרה, חום גבוה או נוקשות שרירים עלול להתרחש. במידה ותופעה זאת מתרחשת, יש לפנות מיידית לרופא ולידע אותו כי את/ה נוטל/ת ריספרדל קונסטטה
- לעיתים נדירות מאד, ייתכן מצב של רמות סוכר גבוהות בדם. אנא פנה/י לרופא אם את/ה סובל/ת מצימאון מוגבר או מתן שתן מוגבר

- במהלך ניתוח קטרקט (מחלה של העין המתבטאת בעכירות של עדשת העין), ייתכן ואישון העין (העיגול השחור במרכז העין) לא יגדל לגודל הרצוי. כמו כן, ייתכן וקשתית העין (החלק הצבעוני בעין) תהפוך לרפוייה במהלך הניתוח וזה עלול לגרום לנזק לעין.
- אם הינך מתכנן לעבור ניתוח בעין, אמור לרופאך כי הינך נוטל תרופה זו.
- בחולים קשישים ובחולים בעלי תפקוד כלייתי או כבדי לקוי יש להיוועץ ברופא כיצד ואיזה מינון ליטול.

לפני הטיפול בריספרדל קונסטה ספר לרופא אם:

- הינך סובל/ת או סבלת בעבר מליקוי בתפקוד הלב, ביחוד הפרעות בקצב הלב, פעילות חשמלית בלתי תקינה בלב או אם הנך נוטל/ת תרופות אשר משנות את הפעילות החשמלית בלב. – יש להשתמש בריספרדל קונסטה בזהירות ורק לאחר היוועצות ברופא.
- אתה נוטל תרופות לטיפול ביתר לחץ דם מכיוון שלחץ דם נמוך עלול להיגרם משימוש בו זמני של ריספרדל קונסטה ותרופות להורדת לחץ הדם.
- את/ה או מישהו מבני משפחתך סובלים או סבלו בעבר מקרישי דם. קרישי דם בריאות וברגליים נצפו במטופלים שנטלו ריספרדל קונסטה. קרישי דם בריאות עלולים להיות קטלניים.
- סבלת בעבר מספירה נמוכה של תאי דם לבנים (גם אם נגרמה עקב שימוש בתרופות אחרות) מכיוון שלעיתים נדירות, נצפתה רמה נמוכה מאד של תאי דם לבנים (הנדרשים להגנה מפני זיהומים) במטופלים שנטלו ריספרדל קונסטה. הרופא עשוי לבצע בדיקות דם לצורך בדיקת רמת תאי הדם הלבנים.
- הינך סובל/ת ממחלת לב או כלי דם, מסוכרת, מפרקינסון, מדמנציה הקשורה לגופי לואי או מאפילפסיה. ייתכן ויהיה צורך בהשגחה רפואית בזמן שהנך מקבל/ת ריספרדל קונסטה וייתכן שיהיה צורך בהתאמת המנה או הטיפול.

אם אתה לוקח, או אם לקחת לאחרונה, תרופות אחרות כולל תרופות ללא מרשם ותוספי תזונה, ספר על כך לרופא או לרוקח.

ריספרדל קונסטה עלולה להגביר השפעת תרופות המפחיתות את יכולת התגובה שלך (תרופות להרגעה, משככי כאבים נרקוטיים, אנטיהיסטמינים מסוימים - תרופות מסוימות לטיפול באלרגיה, נוגדי דיכאון מסוימים). יש ליטול תרופות אלו רק אם נרשמו על ידי הרופא.

התרופות הבאות עלולות לשנות את השפעת ריספרדל קונסטה על כן יש ליידע את הרופא אם התחלת או הפסקת ליטול

תרופות אלה:

- תרופות לטיפול במחלת פרקינסון כמו אגוניסטים של דופמין (לדוגמה לבודופה).
- תרופות לטיפול בלחץ דם גבוה, יש להוועץ ברופא משום שניטלתן ביחד עם ריספרדל קונסטה עלולה לגרום ללחץ הדם לרדת לרמה נמוכה מדי.
- תרופות שעלולות לשנות את הפעילות החשמלית של הלב כמו למשל (אך לא רק) תרופות לטיפול במלריה, בהפרעות קצב לב, באלרגיות, תרופות אנטיפסיכיות אחרות, נוגדי דיכאון, תכשירים משתנים או תרופות אחרות המשפיעות על רמת המלחים בגוף (נתרן, אשלגן, מגנזיום) - יש להשתמש בריספרדל קונסטה בזהירות.
- קרבמזפין, תרופה המשמשת בעיקר לטיפול באפילפסיה או בהתקפי כאב חזקים בפנים (trigeminal neuralgia). תרופה זו עלולה להוריד את רמת ריספרדל קונסטה בדם.
- פלאוקסטין ופארוקסטין המשמשות בעיקר לטיפול בדיכאון ובמגוון הפרעות חרדה. תרופות אלה עלולות להעלות את רמת ריספרדל קונסטה בדם. לכן, יש לדווח לרופא אם התחלת/או הפסקת ליטול פלאוקסטין או פארוקסטין.
- פורוסמיד, (ראה סעיף – "אזהרות מיוחדות הנוגעות לשימוש בתרופה:")

הסבירות כי התרופות הבאות ישנו את השפעת ריספרדל קונסטה, נמוכה:

סימטידין ורנטידין, שתי תרופות המשמשות להורדת חומציות הקיבה עלולות לעלות מעט את רמת ריספרדל קונסטה בדם אך לא סביר שישנו את השפעתה.

לאריתרומיצין, אנטיביוטיקה ממשפחת המאקרולידים, אין השפעה על רמת ריספרדל קונסטה בדם.

לטופירמאט, המשמשת לטיפול באפילפסיה ומיגרנה, אין השפעה משמעותית על רמת ריספרדל קונסטה בדם.

הסבירות כי ריספרדל קונסטטה תשנה את השפעת התרופות הבאות, נמוכה:
לריספרדל קונסטטה לא נראה שיש השפעה על ליתיום או וולפרואט המשמשות לטיפול במאניה או על דיגוקסין, תרופה לטיפול בבעיות לב.

שימוש בתרופה וצריכת אלכוהול

אין לשתות יינות או משקאות חריפים בתקופת הטיפול עם התרופה, התרופה עלולה להגביר את השפעת האלכוהול.

הריון והנקה

-אם הינך בהריון או מתכננת להכנס להריון, יש להוועץ ברופא אשר יחליט האם מותר לך להשתמש בריספרדל קונסטטה.
רעד, נוקשות שרירים ו/או חולשה, ישנוניות, חוסר שקט, קשיי נשימה או קושי בהזנה עלולים להתרחש בוולד של אם שהשתמשה בריספרדל קונסטטה בשליש האחרון של ההריון.
-אל תשתמשי בתכשיר כאשר הינך מניקה. היוועצי ברופא במקרה זה.

נהיגה ושימוש במכונית

התרופה עלולה להשפיע על עירנותך או על יכולתך לנהוג. **אין לנהוג או להפעיל מכונית מסוכנות בזמן השימוש בתרופה** ~~לכן מומלץ לא לנהוג או להפעיל מכונית~~, לפני שרופאך יעריך את השפעת התרופה עליך.

3. כיצד תשתמש בתרופה?

תמיד יש להשתמש לפי הוראות הרופא.
עליך לבדוק עם הרופא או הרוקח עם אינך בטוח.
המינון ואופן הטיפול יקבעו על ידי הרופא בלבד.
ריספרדל קונסטטה ניתנת בזריקה תוך שרירית לעוז או אל שריר הזרוע כל שבועיים על ידי איש צוות רפואי. יש להזריק לחלופין פעם בצד ימין ופעם בצד שמאל של הגוף. אין להזריק דרך הוריד.
המינון המקובל בדרך כלל הוא 25 מ"ג בהזרקה תוך שרירית, כל שבועיים. יתכן ויהיה צורך במינון גבוה יותר (37.5 מ"ג או 50 מ"ג).
יתכן והרופא יורה לך לקחת גם ריספרדל בטבליות למשך שלושת השבועות הראשונים לאחר מתן הזריקה הראשונה.
אין לעבור על המנה המומלצת.

אם נטלת בטעות מינון גבוה יותר

מינון יתר סביר פחות בזריקות ריספרדל קונסטטה מאשר בלקיחת ריספרדל בבליעה (כגון בכדורים, תמיסה).
מידע הנוגע למינון יתר של ריספרדל בבליעה מובא כאן:
במקרים של מינון יתר אחד או יותר מהסימנים הבאים עלול להתרחש: ירידה בהכרה, נמנום, ישנוניות, רעד מוגזם, נוקשות שרירים, עליה בקצב הלב ולחץ דם נמוך. ישנם דיווחים על מקרים של הולכה חשמלית לא תקינה בלב (הארכת מקטע QT) ופרוסים. מקרים של מינון יתר יכולים להתרחש גם אם נוטלים תרופות נוספות יחד עם ריספרדל.
אם הנך חווה את אחד הסימפטומים שתוארו או אם נטל ילד בטעות מן התרופה פנה מיד לרופא או לחדר מיון של בית חולים והבא אריזת התרופה איתך.

אם שכחת ליטול את התרופה

אם שכחת ליטול תרופה זו בזמן קצוב יש להתייעץ עם הרופא או האחיות במרפאה בה אתה מטופל/ת.
יש להתמיד בטיפול שהומלץ על ידי הרופא.
גם אם חל שיפור במצב בריאותך אין להפסיק הטיפול בתרופה אלא בהתייעצות עם הרופא ובאופן מבוקר.
אין ליטול תרופות בחושך! בדוק התווית והמנה בכל פעם שהינך נוטל תרופה. הרכב משקפיים אם הינך זקוק להם.
אם יש לך שאלות נוספות בנוגע לשימוש בתרופה, היוועץ ברופא או ברוקח.

תופעות לוואי

כמו לכל תרופה, השימוש בריספרדל קונסטת עלול לגרום לתופעות לוואי בחלק מהמשתמשים. אל תיבהל למקרא רשימת תופעות הלוואי. יתכן ולא תסבול מאף אחת מהן.

רשומות מטה תופעות הלוואי הקשורות בטיפול בריספרדל קונסטת. במידה ואחד התסמינים המפורטים הופיעו אנא היוועץ ברופא:

תופעות הלוואי שכיחות מאד הנפוצות ביותר – (תופעות שמופיעות ביותר ממשמש אחד מעשרה מעל 1 מתוך 10 מטופלים):

- תסמיני הצטננות
- קושי בהירדמות או קושי בשינה רצופה
- דיכאון, חרדה
- פרקינסוניזם המתבטא ב: תנועתיות לקויה או איטית, תחושת נוקשות שרירים או התכווצות שרירים ולעיתים אף תחושה של קפאון בתנועה וצורך בהתחלת תנועה מחודשת. גרירת רגליים איטית, רעד במנוחה, הפרשת יתר של רוק ו/או הגברת הריוור ואיבוד הבעה בפנים.
- כאב ראש

תופעות לוואי שכיחות (תופעות שמופיעות ב-10-1 משתמשים מתוך 100):

- דלקת ריאות, דלקת סימפונות (ברונכיטיס), זיהום בסינוסים, זיהום בדרכי השתן, מחלה דמוית שפעת.
- אנמיה
- ריספרדל קונסטת עלול להעלות את רמות ההורמון פרולקטין כפי שניתן לגלות בבדיקות דם, אשר יכולות, אך לא בהכרח, לגרום להופעת תסמינים. תסמינים של רמות גבוהות של פרולקטין כוללים: אצל גברים- התנפחות של השדיים; קושי להגיע לזקפה או לשמור עליה או כל בעיה אחרת בתפקוד המיני. אצל נשים – תחושת חוסר נוחות בשדיים, הפרשת חלב מהשדיים, העדר ווסת או הפרעות אחרות של המחזור החודשי.
- רמות סוכר גבוהות בדם, עלייה במשקל, ירידה במשקל, ירידה או עלייה בתאבון
- בעיות שינה, עצבנות, ירידה בחשק המיני, חוסר מנוחה, תחושת ישנוניות או ערנות נמוכה
- דיסטוניה – תופעה המערבת התכווצות שרירים איטית או ממושכת ולא רצונית של השרירים. למרות שתופעה זו יכולה לערב כל חלק בגוף (ויכולה להתבטא ביציבה לא תקינה), בדרך כלל יושפעו שרירי הפנים. התופעה כוללת תנועות לא תקינות של העיניים, הפה, הלשון או הלסת.
- סחרחורת
- דיסקינזיה – תנועת שרירים לא רצונית שעלולה לכלול תנועות חוזרות, עוויתיות או התפתלויות.
- רעד
- טשטוש ראייה
- קצב לב מהיר
- לחץ דם נמוך, לחץ דם גבוה
- קוצר נשימה, כאב גרון, שיעול, וגודש באף
- כאב בטן או אי נוחות בבטן, הקאה, זהום במערכת העיכול, עצירות, שלשול, בעיות עיכול, יובש בפה וכאבי שיניים
- פריחה
- התכווצויות שרירים, כאבי שרירים או עצמות, כאב גב, כאב מפרקים
- דליפת שתן (חוסר יכולת להתאפק)
- בעיות בזקפה
- העדר וסת
- דליפת חלב מהשדים
- נפיחות בגוף, בידיים או ברגליים, חום, אי נוחות בחזה, חולשה, עייפות
- כאב
- תגובה באזור ההזרקה, הכוללת גרד, כאב או נפיחות
- עלייה ברמות אנזימי כבד בדם
- נפילות

תופעות לוואי שאינן שכיחות (תופעות שמופיעות ב-10-1 משתמשים מתוך 1000):

- זיהום בדרכי הנשימה, זיהום בשלפוחית השתן, זיהום אוזניים, זיהום עיניים, דלקת שקדים, זיהום פטרייתי בציפורניים, זיהום בעור, זיהום המוגבל לאזור מסוים בעור או בחלק מהגוף, זיהום ויראלי, דלקת בעור כתוצאה מחשיפה לקרדית, מורסה (אבצס) תחת העור
- ירידה בספירת תאי דם לבנים, ירידה ברמת טסיות (תאי דם המסייעים בעצירת דימום), ירידה בספירת תאי דם אדומים
- תגובה אלרגית
- המצאות סוכר בשתן, סוכרת או החמרה של סוכרת
- אובדן תאבון שעלול להוביל לתת תזונה וירידה במשקל
- עלייה ברמות טריגליצרידים ו/או כולסטרול (שומנים) בדם
- מצב רוח מרומם (מאניה), בלבול, קושי בהגעה לאורגזמה, סיטום
- הפרעת תנועה מאוחרת (Tardive dyskinesia) – תנועות ו/או עוויתות לא נשלטות של הפנים, הלשון או חלקים אחרים בגוף. במידה את/ה חווה תנועות בלתי רצוניות וקצביות של הלשון, הפה והפנים פנה/י מיידית לרופא. יתכן והרופא יורה להפסיק את הטיפול בריספרדל קונסטה
- הפסקה פתאומית של זרימת דם למוח (שבץ או מיני-שבץ)
- אובדן הכרה, פרכוסים, התעלפות
- דחף בלתי נשלט להניע חלקי גוף מסוימים, הפרעות בשווי משקל, קואורדינציה לא תקינה, סחרחורת במעבר למצב עמידה, הפרעה בתשומת הלב, בעיות בדיבור, אובדן או בעיות בחוש הטעם, ירידה ברגישות העור לכאב ומגע, תחושת עקצוץ או נמלול של העור
- דלקת עיניים, דלקת בלחמית העין, יובש בעיניים, ריבוי דמעות, אדמומיות בעיניים.
- תחושת סחרור (ורטיגו), צלצולים באוזניים, כאב אוזניים
- פרפור פרודוריים (קצב לב לא סדיר), הפרעה בהולכה שבין החלק העליון לחלק התחתון של הלב, הולכה חשמלית לא תקינה של הלב, הארכת מרווח QT של הלב, קצב לב איטי, בדיקה לא תקינה של המתח החשמלי בלב (אלקטרוקרדיוגרם/ECG), מודעות לפעימות לב לא תקינות (פלפיטציות)
- לחץ דם נמוך במעבר לעמידה (כתוצאה מכך, אנשים מסוימים הנוטלים ריספרדל קונסטה עלולים לחוש חולשה, סחרחורת או עלולים להתעלף במעבר למצב עמידה או ישיבה באופן פתאומי)
- נשימה מהירה ושטחית, גודש בדרכי נשימה, צפצופים, דמם האף
- חוסר שליטה (חוסר יכולת להתאפק) במתן צואה, קושי בבליעה, הגברה של גזים במערכת העיכול
- גירוד, אובדן שיער, אקזמה, יובש בעור, אדמומיות בעור, שינוי צבע העור, אקנה, קשקשים
- עלייה ברמות CPK (קראטין פוספוקינאז) בדם, אנזים המשתחרר כתוצאה מפגיעה או נזק בשריר
- קשיון מפרקים, התנפחות מפרקים, חולשת שרירים, כאב צוואר
- תכיפות במתן שתן, חוסר יכולת לתת שתן, כאבים במתן שתן
- הפרעות בפליטת זרע
- איחור בווסת, העדר ווסת או כל הפרעה אחרת הקשורה למחזור החודשי
- התפתחות שדיים בגברים, חוסר תפקוד מיני, אי נוחות בשדיים, הפרשה מהנרתיק
- התנפחות הפנים, הפה, העיניים או השפתיים
- צמרמורות, עלייה בטמפרטורת הגוף
- שינוי בצורת ההליכה
- תחושת צמא, תחושה כללית לא טובה, מצב רוח ירוד
- התקשות העור
- עלייה ברמות אנזימי כבד בדם
- כאב בזמן קבלת טיפול

תופעות לוואי נדירות (תופעות שמופיעות ב-10-1 משתמשים מתוך 10,000):

- ירידה ברמות התאים הלבנים בדם שאחראיים להגן מפני זיהומים
- הפרשה לא תקינה של הורמון המווסת את נפח השתן
- רמות סוכר נמוכות בדם
- שתייה מרובה של מים
- העדר רגש
- תסמונת נירולפטית ממאירה (Neuroleptic malignant syndrome): בלבול, איבוד או ירידה בהכרה, חום גבוה ונוקשות שרירים חמורה
- רמת הכרה/מודעות נמוכה
- רעד של הראש
- הפרעה בתנועת העיניים, גלגול עיניים, רגישות יתר של העיניים לאור
- קצב לב לא תקין
- קרישי דם ברגליים, קרישי דם בריאות
- קשיי נשימה (חוסר יכולת לנשום) בזמן שינה
- דלקת ריאות כתוצאה משאיפת מזון, גודש בריאות,
- קולות נפיצים מהריאות, בעיות בקול, בעיות בדרכי הנשימה
- דלקת בלבב, חסימת מעיים
- פריחה על העור הקשורה לשימוש בתרופה, סרפדת (תגובה אלרגית בעור). התעבות העור, בעיות בעור, חבורות בעור
- פירוק סיבי השריר וכאבי שרירים
- בעיות ביציבה
- הגדלת שדיים, הפרשה מהשדיים
- ירידה בטמפרטורת הגוף, תחושת אי נוחות
- הצהבה של העור והעיניים (צהבת)

תופעות לוואי נדירות מאוד (פחות ממשמש אחד מתוך 10,000):

- סיבוכים מסכני חיים כתוצאה מסוכרת לא מאוזנת
- תגובה אלרגית חמורה מלווה בנפיחות אשר יכולה לערב את הגרון ולהוביל לקשיי נשימה
- במקרים נדירים מאד, תתכן תגובה אלרגית לאחר קבלת זריקה של ריספרדל קונסטה, גם במטופלים שטופלו בריספרדל במתן פומי (דרך הפה) ללא תגובה אלרגית. יש לפנות לטיפול רפואי מיידי אם הינך סובל מפריחה, נפיחות בגרון, גירוד או קשיי נשימה, משום שאלה סימנים לתגובה אלרגית חמורה.
- היעדר תנועתיות שרירים במערכת העיכול הגורמת לחסימה
- בעיות עיניים במהלך ניתוח קטרקט. במהלך ניתוח קטרקט, עלול להתרחש מצב של intraoperative floppy iris syndrome (IFIS) במידה והינך השתמשת בריספרדל קונסטה במהלך שלושת החודשים האחרונים. אם הינך צריך לעבור ניתוח קטרקט, אמור לרופאך אם הינך נוטל ריספרדל קונסטה בשלושה חודשים האחרונים.

תופעות לוואי בעלות תדירות בלתי ידועה:

- ירידה מסוכנת במספר תאי דם לבנים מהסוג הנדרש להגנה מפני זיהומים
- תגובה אלרגית חריפה המאופיינת בחום, נפיחות בפה, בפנים, בשפתיים או בלשון, קוצר נשימה, גירוד, פריחה על העור ולפעמים ירידה בלחץ הדם
- שתיית מים מוגזמת ביותר המסכנת את הגוף
- עלייה ברמת האינסולין בדם (הורמון המווסת את רמות הסוכר בגוף)
- בעיה בכלי הדם במוח

- חוסר תגובה לגירוי
- תרדמת כתוצאה מסוכרת לא מאוזנת
- אובדן ראייה או עיוורון פתאומי
- גלאוקומה (לחץ תוך עיני מוגבר), הווצרות קרום בשולי העפעפיים
- פעימות לב מוגברות במעבר למצב עמידה
- הסמקה, התנפחות הלשון
- צואה קשה מאד
- שפתיים סדוקות
- זקפה ממושכת אשר עלולה לדרוש התערבות כירורגית
- נפיחות של הבלוטות בחזה
- תחושת קור ברגליים ובידיים
- תסמינים של גמילה מתרופות
- דלקת מעיים

תופעות לוואי המחייבות התייחסות מיוחדת :

- במהלך שימוש ממושך, ריספרדל קונסטת עלול לגרום לעויותות לא רצויות בפנים. במידה ותופעה זאת מתרחשת, יש לפנות לרופא
- לעיתים נדירות, מצב של בלבול, ירידה בהכרה, חום גבוה או שרירים נוקשים עלול להתרחש. במידה ותופעה זאת מתרחשת, יש לפנות מיידית לרופא ולידע אותו כי את/ה נוטלת ריספרדל קונסטת

במקרים נדירים דווח על רמת סוכר גבוהה בדם. יש לדווח לרופא אם הנך מרגיש/ה תסמינים כגון צימאון מוגבר או השתנה מוגברת. בחולים קשישים הסובלים מדמנציה נראו מקרי שינוי פתאומי במצב המנטלי או חולשה פתאומית או תחושת נימול של הפנים, הזרועות, או הרגליים ובייחוד בצד אחד של הגוף או מקרי דיבור לא ברור. אם אחד מאלה קרה ואפילו לפרק זמן קצר יש לפנות לעזרה רפואית מיד.

אם הופיעה תופעת לוואי, אם אחת מתופעות הלוואי מחמירה, או כאשר אתה סובל מתופעת לוואי שלא הוזכרה בעלון, עליך להתייעץ עם הרופא.

איך לאחסן את התרופה?

מנע/י הרעלה! תרופה זו וכל תרופה אחרת יש לשמור במקום סגור מחוץ להישג ידם של ילדים ו/או תינוקות ועל ידי-

כך תמנע הרעלה. אל תגרום להקאה ללא הוראה מפורשת מהרופא

אין להשתמש בתרופה אחרי תאריך התפוגה (exp date) המופיע על גבי האריזה. תאריך התפוגה מתייחס ליום האחרון של אותו החודש. בכל מקרה של ספק, עליך להיוועץ ברוקח שסיפק לך את התרופה.

(x) יש לאחסן בקירור: 2°C-8°C . (טווח טמפרטורות זה שורר על פי רוב במקרר ביתי)

גם לפי תנאי האריזה/אחסנה המומלצים, תרופות נשמרות לתקופה מוגבלת בלבד.

אין לאחסן תרופות שונות באותה אריזה. אחסן באריזה המקורית והגן מאור

6. מידע נוסף

נוסף על החומר הפעיל התרופה מכילה גם:

Polymer: 7525 DL JN1 (poly-d,1-lactide-co-glycolide)

בקבוקון:

נזל להרחפה: Carmellose sodium 40 mPa.s, Sodium chloride, Disodium hydrogen phosphate dihydrate, Citric acid anhydrous, polysorbate 20, sodium hydroxide, water for injection.

הערכה כוללת:

- בקבוקון עם risperidone באבקה, להכנת תרחיף להזרקה
- מזרק מוכן לשימוש המכיל 2 מ"ל נוזל להרחפה.
- מתאם להרחפה ללא מחט
- מחט להזרקה לעכוז
- מחט להזרקה לשריר הזרוע

בבקבוקון הריספרידון עשוי מזכוכית שקופה עם פקק גומי בצבע אפור שמעליו פקק פלסטיק צבעוני, ומכיל אבקה בצבע לבן/לבנבן.

המזרק המוכן מכיל תמיסה צלולה ושקופה ללא חלקיקים נראים לעין.

התכשיר הינו פורמולציה בשחרור מושהה וקיים בשלושה מינונים: ריספרדל קונסטטה 25 מ"ג, ריספרדל קונסטטה 37.5 מ"ג וריספרדל קונסטטה 50 מ"ג

מס' רישום התרופה בפנקס התרופות הממלכתי במשרד הבריאות:

ריספרדל קונסטטה 25 מ"ג – 12, -11, 127 28 30619 ,

ריספרדל קונסטטה 37.5 מ"ג – 12, -11, 127 29 30620 ,

ריספרדל קונסטטה 50 מ"ג – 12, -11, 127 30 30621 ,

שם היצרן וכתובתו : סילג בע"מ, שפהאוזן שוויץ

בעל הרישום וכתובתו : ג"י סי הלת' קר בע"מ, קיבוץ שפיים 60990, ישראל.

עלון זה נבדק ואושר ע"י משרד הבריאות בתאריך מאי 2014

לשם הפשטות ולהקלת הקריאה, עלון זה נוסח בלשון זכר. על אף זאת, התרופה מיועדת לבני שני המינים.

WARNING: INCREASED MORTALITY IN ELDERLY PATIENTS WITH DEMENTIA-RELATED PSYCHOSIS

ELDERLY PATIENTS WITH DEMENTIA-RELATED PSYCHOSIS TREATED WITH ANTIPSYCHOTIC DRUGS ARE AT AN INCREASED RISK OF DEATH. ANALYSES OF 17 PLACEBO-CONTROLLED TRIALS (MODAL DURATION OF 10 WEEKS), LARGELY IN PATIENTS TAKING ATYPICAL ANTIPSYCHOTIC DRUGS, REVEALED A RISK OF DEATH IN DRUG-TREATED PATIENTS OF BETWEEN 1.6 TO 1.7 TIMES THE RISK OF DEATH IN PLACEBO-TREATED PATIENTS. OVER THE COURSE OF A TYPICAL 10 WEEK CONTROLLED TRIAL, THE RATE OF DEATH IN DRUG-TREATED PATIENTS WAS ABOUT 4.5%, COMPARED TO A RATE OF ABOUT 2.6% IN THE PLACEBO GROUP. ALTHOUGH THE CAUSES OF DEATH WERE VARIED, MOST OF THE DEATHS APPEARED TO BE EITHER CARDIOVASCULAR (E.G., HEART FAILURE, SUDDEN DEATH) OR INFECTIOUS (E.G., PNEUMONIA) IN NATURE. OBSERVATIONAL STUDIES SUGGEST THAT, SIMILAR TO ATYPICAL ANTIPSYCHOTIC DRUGS, TREATMENT WITH CONVENTIONAL ANTIPSYCHOTIC DRUGS MAY INCREASE MORTALITY. THE EXTENT TO WHICH THE FINDINGS OF INCREASED MORTALITY IN OBSERVATIONAL STUDIES MAY BE ATTRIBUTED TO THE ANTIPSYCHOTIC DRUG AS OPPOSED TO SOME CHARACTERISTIC(S) OF THE PATIENTS IS NOT CLEAR. RISPERDAL[®] CONSTA[®] (RISPERIDONE) IS NOT APPROVED FOR THE TREATMENT OF PATIENTS WITH DEMENTIA-RELATED PSYCHOSIS. [SEE WARNINGS AND PRECAUTIONS (5.1)]

1 INDICATIONS AND USAGE**1.1 SCHIZOPHRENIA**

RISPERDAL[®] CONSTA[®] (risperidone) is indicated for the treatment of schizophrenia and schizoaffective disorders.(see Clinical studies (14.1))

~~1.2 Bipolar Disorder~~

~~RISPERDAL[®] CONSTA[®] (risperidone) is indicated as monotherapy or as adjunctive therapy for the maintenance treatment of bipolar I disorder to delay occurrence of mood episodes.(see clinical studies (14.2, 14.3))~~

Risperdal consta is indicated as monotherapy for the maintenance treatment of bipolar I disorder to delay occurrence of mood episodes.

Risperdal consta is indicated for adjunctive maintenance treatment to delay occurrence of mood episodes in patients with frequently relapsing bipolar disorder.

2 DOSAGE AND ADMINISTRATION

For patients who have never taken oral RISPERDAL[®], it is recommended to establish tolerability with oral RISPERDAL[®] prior to initiating treatment with RISPERDAL[®] CONSTA[®].

RISPERDAL[®] CONSTA[®] should be administered every 2 weeks by deep intramuscular (IM) deltoid or gluteal injection. Each injection should be administered by a health care professional using the appropriate enclosed safety needle [see *Dosage and Administration* (2.8)]. For deltoid administration, use the 1-inch needle alternating injections between the two arms. For gluteal administration, use the 2-inch needle alternating injections between the two buttocks. Do not administer intravenously.

2.1 Schizophrenia

The recommended dose for the treatment of schizophrenia is 25 mg IM every 2 weeks. Although dose response for effectiveness has not been established for RISPERDAL[®] CONSTA[®], some patients not responding to 25 mg may benefit from a higher dose of 37.5 mg or 50 mg. The maximum dose should not exceed 50 mg RISPERDAL[®] CONSTA[®] every 2 weeks. No additional benefit was observed with dosages greater than 50 mg RISPERDAL[®] CONSTA[®]; however, a higher incidence of adverse effects was observed.

The efficacy of RISPERDAL[®] CONSTA[®] in the treatment of schizophrenia has not been evaluated in controlled clinical trials for longer than 12 weeks. Although controlled studies have not been conducted to answer the question of how long patients with schizophrenia should be treated with RISPERDAL[®] CONSTA[®], oral risperidone has been shown to be effective in delaying time to relapse in longer term use. It is recommended that responding patients be continued on treatment with RISPERDAL[®] CONSTA[®] at the lowest dose needed. The physician who elects to use RISPERDAL[®] CONSTA[®] for extended periods should periodically re-evaluate the long-term risks and benefits of the drug for the individual patient.

2.2 Bipolar Disorder

The recommended dose for monotherapy or adjunctive therapy to lithium or valproate for the maintenance treatment of Bipolar I Disorder is 25 mg IM every 2 weeks. Some patients may benefit from a higher dose of 37.5 mg or 50 mg. Dosages above 50 mg have not been studied in this population. The physician who elects to use RISPERDAL[®] CONSTA[®] for extended periods should periodically re-evaluate the long-term risks and benefits of the drug for the individual patient.

2.3 General Dosing Information

A lower initial dose of 12.5 mg may be appropriate when clinical factors warrant dose adjustment, such as in patients with hepatic or renal impairment, for certain drug interactions that increase risperidone plasma concentrations [see DRUG INTERACTIONS (7.11)] or in patients who have a history of poor tolerability to psychotropic medications. The efficacy of the 12.5 mg dose has not been investigated in clinical trials.

Oral RISPERDAL[®] (or another antipsychotic medication) should be given with the first injection of RISPERDAL[®] CONSTA[®] and continued for 3 weeks (and then discontinued) to ensure that adequate therapeutic plasma concentrations are maintained prior to the main release phase of risperidone from the injection site [see *Clinical Pharmacology* (12.3)].

Upward dose adjustment should not be made more frequently than every 4 weeks. The clinical effects of this dose adjustment should not be anticipated earlier than 3 weeks after the first injection with the higher dose.

In patients with clinical factors such as hepatic or renal impairment or certain drug interactions that increase risperidone plasma concentrations [see DRUG INTERACTIONS (7.11)], dose reduction as low as 12.5 mg may be appropriate. The efficacy of the 12.5 mg dose has not been investigated in clinical trials.

Do not combine two different dose strengths of RISPERDAL[®] CONSTA[®] in a single administration.

2.4 Dosage in Special Populations

Elderly

For elderly patients treated with RISPERDAL[®] CONSTA[®], the recommended dosage is 25 mg IM every 2 weeks. Oral RISPERDAL[®] (or another antipsychotic medication) should be given with the first injection of RISPERDAL[®] CONSTA[®] and should be continued for 3 weeks to ensure that adequate therapeutic plasma concentrations are maintained prior to the main release phase of risperidone from the injection site [see *Clinical Pharmacology* (12.3)].

Renal or Hepatic Impairment

Patients with renal or hepatic impairment should be treated with titrated doses of oral RISPERDAL[®] prior to initiating treatment with RISPERDAL[®] CONSTA[®]. The recommended starting dose is 0.5 mg oral RISPERDAL[®] twice daily during the first week, which can be increased to 1 mg twice daily or 2 mg once daily during the second week. If a total daily dose of at least 2 mg oral RISPERDAL[®] is well tolerated, an injection of 25 mg RISPERDAL[®] CONSTA[®] can be administered every 2 weeks. Oral supplementation should be continued for 3 weeks after the first injection until the main release of risperidone from the injection site has begun. In some patients, slower titration may be medically appropriate. Alternatively, a starting dose of RISPERDAL[®] CONSTA[®] of 12.5 mg may be appropriate. The efficacy of the 12.5 mg dose has not been investigated in clinical trials.

Patients with renal impairment may have less ability to eliminate risperidone than normal adults. Patients with impaired hepatic function may have an increase in the free fraction of risperidone, possibly resulting in an enhanced effect [see *Clinical Pharmacology* (12.3)]. Elderly patients and patients with a predisposition to hypotensive reactions or for whom such reactions would pose a particular risk should be instructed in nonpharmacologic interventions that help to reduce the occurrence of orthostatic hypotension (e.g., sitting on the edge of the bed for several minutes before attempting to stand in the morning and slowly rising from a seated position). These patients should avoid sodium depletion or dehydration, and circumstances that accentuate hypotension (alcohol intake, high ambient temperature, etc.). Monitoring of orthostatic vital signs should be considered [see *Warnings and Precautions* (5.7)].

2.5 Reinitiation of Treatment in Patients Previously Discontinued

There are no data to specifically address reinitiation of treatment. When restarting patients who have had an interval off treatment with RISPERDAL[®] CONSTA[®], supplementation with oral RISPERDAL[®] (or another antipsychotic medication) should be administered.

2.6 Switching from Other Antipsychotics

There are no systematically collected data to specifically address switching patients from other antipsychotics to RISPERDAL[®] CONSTA[®], or concerning concomitant administration with other

antipsychotics. Previous antipsychotics should be continued for 3 weeks after the first injection of RISPERDAL® CONSTA® to ensure that therapeutic concentrations are maintained until the main release phase of risperidone from the injection site has begun [see *Clinical Pharmacology (12.3)*]. For patients who have never taken oral RISPERDAL®, it is recommended to establish tolerability with oral RISPERDAL® prior to initiating treatment with RISPERDAL® CONSTA®. As recommended with other antipsychotic medications, the need for continuing existing EPS medication should be re evaluated periodically.

2.7 Co-Administration of RISPERDAL® CONSTA® with Certain Other Medications

Co-administration of carbamazepine and other CYP 3A4 enzyme inducers (e.g., phenytoin, rifampin, phenobarbital) with risperidone would be expected to cause decreases in the plasma concentrations of the sum of risperidone and 9-hydroxyrisperidone combined, which could lead to decreased efficacy of RISPERDAL® CONSTA® treatment. The dose of risperidone needs to be titrated accordingly for patients receiving these enzyme inducers, especially during initiation or discontinuation of therapy with these inducers [see *Drug Interactions (7.11)*]. At the initiation of therapy with carbamazepine or other known CYP 3A4 hepatic enzyme inducers, patients should be closely monitored during the first 4-8 weeks, since the dose of RISPERDAL® CONSTA® may need to be adjusted. A dose increase, or additional oral RISPERDAL®, may need to be considered. On discontinuation of carbamazepine or other CYP 3A4 hepatic enzyme inducers, the dosage of RISPERDAL® CONSTA® should be re-evaluated and, if necessary, decreased. Patients may be placed on a lower dose of RISPERDAL® CONSTA® between 2 to 4 weeks before the planned discontinuation of carbamazepine or other CYP 3A4 inducers to adjust for the expected increase in plasma concentrations of risperidone plus 9-hydroxyrisperidone. For patients treated with the recommended dose of 25 mg RISPERDAL® CONSTA® and discontinuing from carbamazepine or other CYP3A4 enzyme inducers, it is recommended to continue treatment with the 25-mg dose unless clinical judgment necessitates lowering the RISPERDAL® CONSTA® dose to 12.5 mg or necessitates interruption of RISPERDAL® CONSTA® treatment. The efficacy of the 12.5 mg dose has not been investigated in clinical trials.

Fluoxetine and paroxetine, CYP 2D6 inhibitors, have been shown to increase the plasma concentration of risperidone 2.5-2.8 fold and 3-9 fold respectively. Fluoxetine did not affect the plasma concentration of 9-hydroxyrisperidone. Paroxetine lowered the concentration of 9-hydroxyrisperidone by about 10%. The dose of risperidone needs to be titrated accordingly when fluoxetine or paroxetine is co-administered. When either concomitant fluoxetine or paroxetine is initiated or discontinued, the physician should re-evaluate the dose of RISPERDAL® CONSTA®. When initiation of fluoxetine or paroxetine is considered, patients may be placed on a lower dose of RISPERDAL® CONSTA® between 2 to 4 weeks before the planned start of fluoxetine or paroxetine therapy to adjust for the expected increase in plasma concentrations of risperidone. When fluoxetine or paroxetine is initiated in patients receiving the recommended dose of 25 mg RISPERDAL® CONSTA®, it is recommended to continue treatment with the 25 mg dose unless clinical judgment necessitates lowering the RISPERDAL® CONSTA® dose to 12.5 mg or necessitates interruption of RISPERDAL® CONSTA® treatment. When RISPERDAL® CONSTA® is initiated in patients already receiving fluoxetine or paroxetine, a starting dose of 12.5 mg can be considered. The efficacy of the 12.5 mg dose has not been investigated in clinical trials. The effects of discontinuation of concomitant fluoxetine or paroxetine therapy on the pharmacokinetics of risperidone and 9-hydroxyrisperidone have not been studied. [see *Drug Interactions (7.11)*]

2.6 Instructions for Use

Dose pack components include:

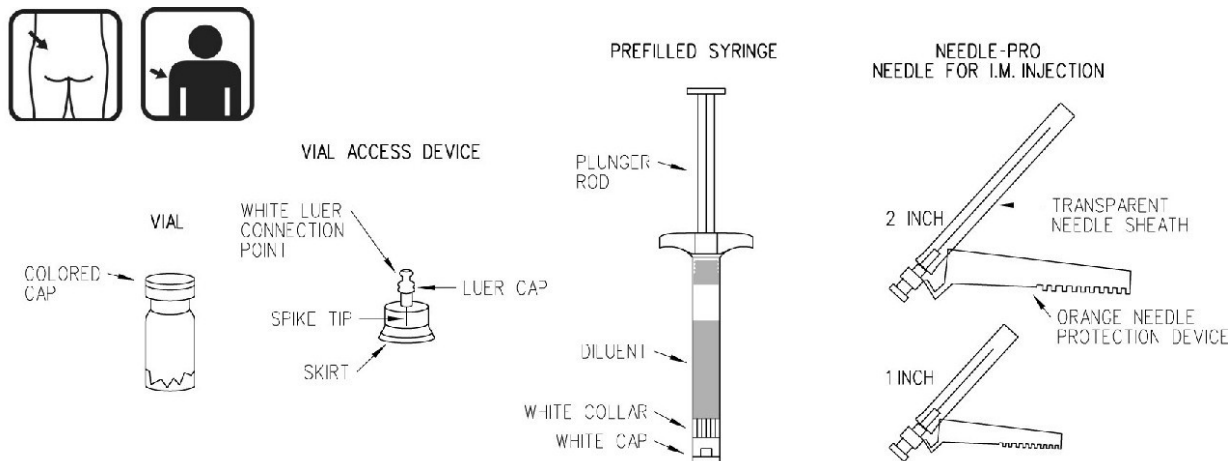

RISPERDAL® CONSTA® requires close attention to the step-by-step 'Instructions for Use' to help avoid difficulties in the use of the kit.

RISPERDAL® CONSTA® must be reconstituted **only** in the diluent supplied in the dose pack, and must be administered with **only** the appropriate needle supplied in the dose pack for gluteal (2-inch needle) or deltoid (1-inch needle) administration. All components are required for administration. Do not substitute any components of the dose pack. To assure that the intended dose of risperidone is delivered, the full contents from the vial must be administered. Administration of partial contents may not deliver the intended dose of risperidone. It is recommended to administer immediately after reconstitution

Remove the dose pack of RISPERDAL® CONSTA® from the refrigerator and allow it to come to room temperature for approximately 30 minutes prior to reconstitution.

1. Flip off the plastic colored cap from the vial. Do not remove the grey rubber stopper. Wipe the top of the grey rubber stopper with an alcohol wipe and allow to dry.

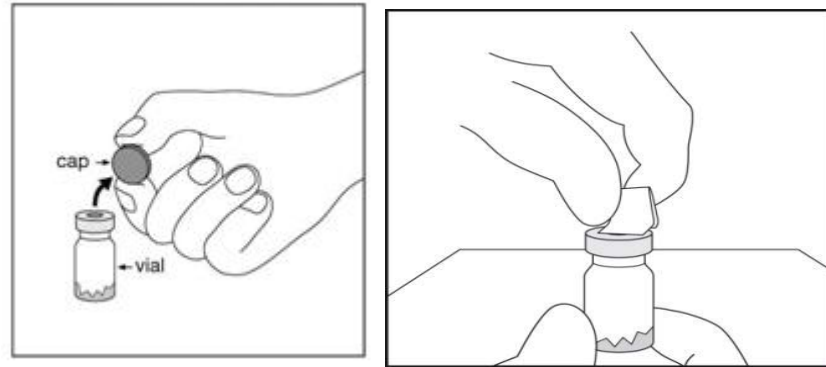

2. Peel back the blister pouch and remove the SmartSite® Needle-Free Vial Access Device by holding between the white luer cap and the skirt. Do not touch the spike tip of the access device at any time.

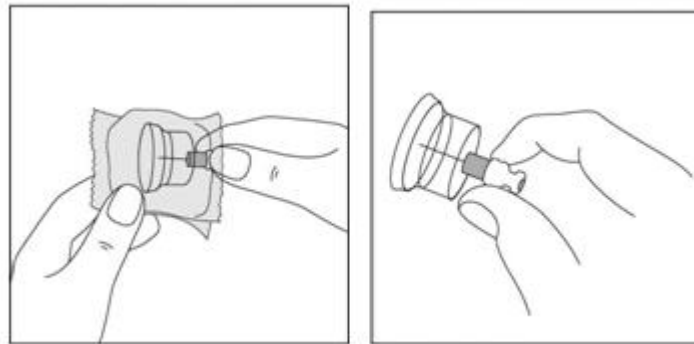

3. It is very important that the SmartSite® Needle-Free Vial Access Device be placed on the vial correctly or the diluent could leak upon transfer to the vial

Place vial on a hard surface. Hold the base of the vial. Orient the SmartSite® Access Device vertically over the vial so that the spike tip is at the center of the vial's rubber stopper.

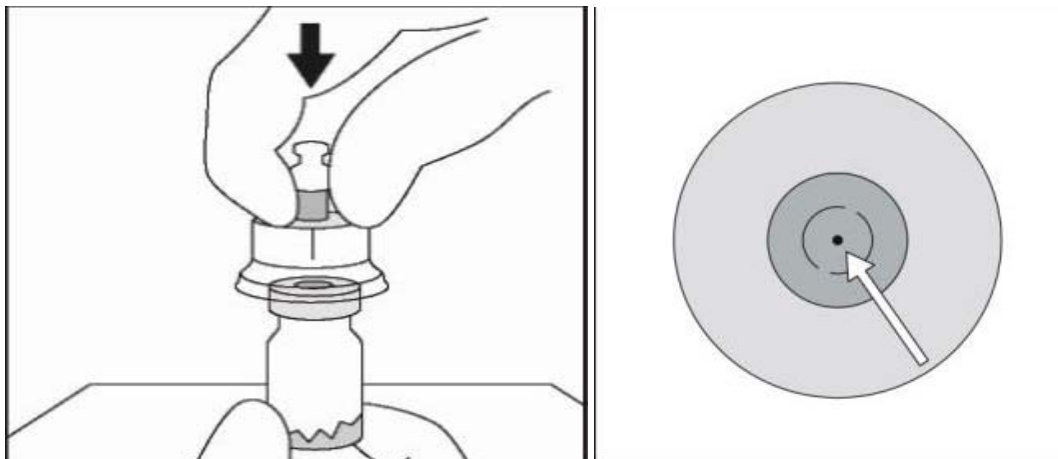

With a straight downward push, press the spike tip of the SmartSite® Needle-Free Vial Access Device through the center of the vial's rubber stopper until the device securely snaps onto the vial top.

Correct

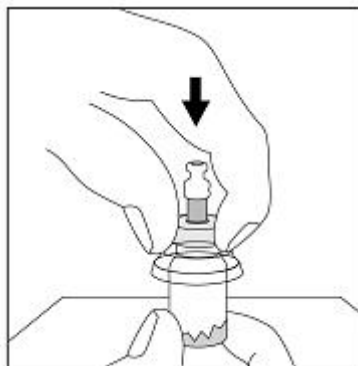

Incorrect

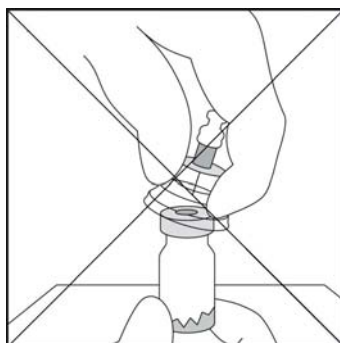

4. **Hold the base of the vial and** Swab the syringe connection point (blue circle) of the SmartSite® Needle-Free Vial Access Device with an alcohol wipe and allow to dry prior to attaching the syringe to the SmartSite® Needle-Free Vial Access Device.



5. The prefilled syringe has a white tip consisting of 2 parts: a white collar and a smooth white cap. To open the syringe, hold the syringe by the white collar and **snap** off the smooth white cap (**DO NOT TWIST OFF THE WHITE CAP**). Remove the white cap together with the rubber tip cap inside.



For all syringe assembly steps, hold the syringe only by the white collar, located at the tip of the syringe. Holding the white collar will help to prevent the white collar from getting detached and ensure a good connection to the syringe. Be careful to not overtighten components when assembling. Overtightening connections may cause syringe component parts to loosen from the syringe body.

6. While holding the **white collar** of the syringe, insert and press the syringe tip into the blue circle of the SmartSite® Needle-Free Vial Access Device and **twist** in a clockwise motion to secure the connection of the syringe to the SmartSite® Needle-Free Vial Access Device (avoid over-twisting). Hold the skirt of the SmartSite® Needle-Free Vial Access Device during attachment to prevent it from spinning. Keep the syringe and SmartSite® Needle-Free Vial Access Device aligned.

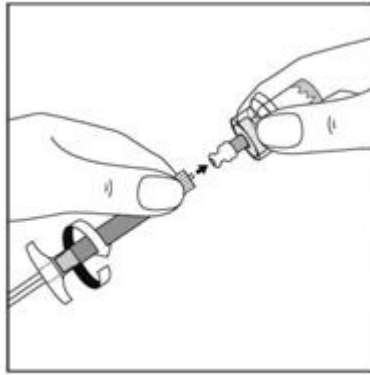

7. Inject the entire contents of the syringe containing the diluent into the vial.

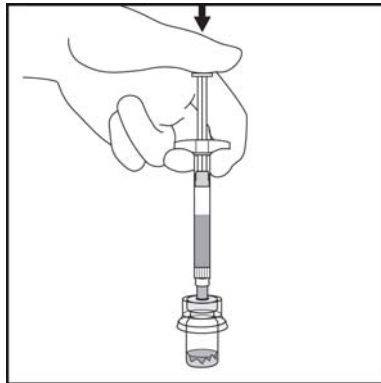

8. Shake the vial **VIGOROUSLY** while holding the plunger rod down with the thumb for a minimum of 10 seconds to ensure a homogeneous suspension. When properly mixed, the suspension appears uniform, thick, and milky in color. The microspheres will be visible in liquid, but no dry microspheres remain.

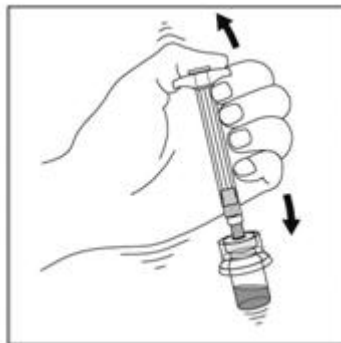

Do not store the vial after reconstitution or the suspension may settle.

.9 Invert the vial completely and **slowly** withdraw the entire content of the suspension from the vial into the syringe. Tear the section of the vial label at the perforation and apply the detached label to syringe for identification purposes.

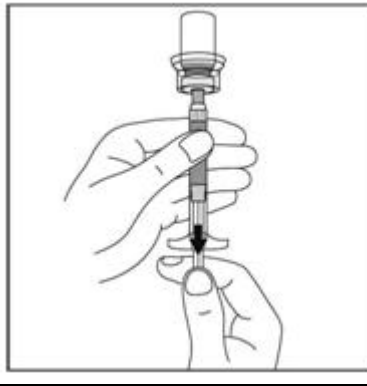

10. While holding the **white collar** of the syringe, unscrew the syringe from the SmartSite[®] Needle-Free Vial Access Device. Discard both the vial and vial access device appropriately.

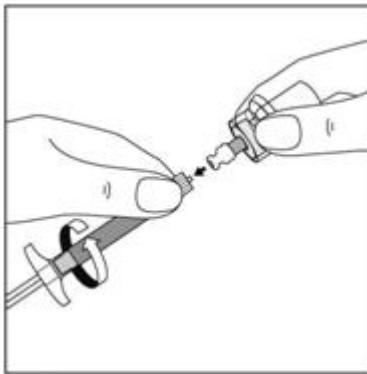

11. Select the appropriate needle provided with the kit:

For GLUTEAL injection, select the **20G TW 2-inch** needle (longer needle with **yellow** colored hub in blister with **yellow** print)

For DELTOID injection, select the **21G UTW 1-inch** needle (shorter needle with **green** colored hub in blister with **green** print)

12 Peel the blister pouch of the Needle-Pro[®] safety device open halfway. Grasp the transparent needle sheath using the plastic peel pouch. To prevent contamination, be careful not to touch the orange Needle-Pro[®] safety device's luer connector. While holding the **white collar** of the syringe, attach the luer connection of the orange Needle-Pro[®] safety device to the syringe with an easy clockwise twisting motion.

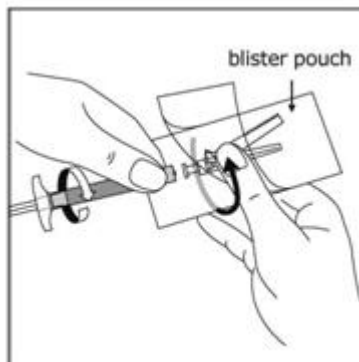

13. While continuing to hold the **white collar** of the syringe, grasp the transparent needle sheath and seat the needle firmly on the orange Needle-Pro® safety device with a push and a clockwise twist. **Seating the needle is an important step to secure the connection between the needle and the orange Needle-Pro® safety device**

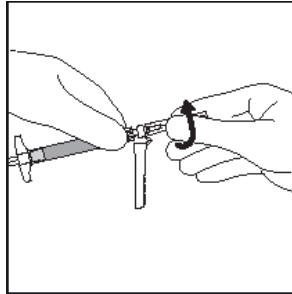

14. *Resuspension of . RISPERDAL® CONSTA®* will be necessary prior to administration, as settling will occur over time once product is reconstituted. Resuspend the microspheres in the syringe by shaking vigorously

- 15 While holding the **white collar** of the syringe, pull the transparent needle sheath straight away from the needle. **DO NOT TWIST** the sheath as the luer connections may be loosened.

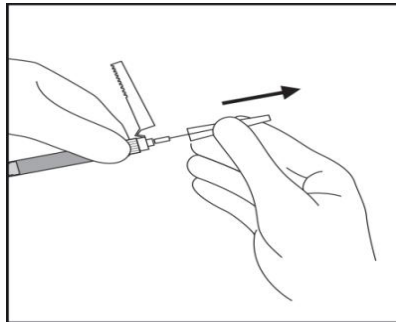

16. Tap the syringe gently to make any air bubbles rise to the top. Remove air in syringe by depressing the plunger rod carefully and slowly, while holding the needle in an upright position. Inject the entire contents of the syringe intramuscularly (IM) into the selected gluteal or deltoid muscle of the patient immediately.. Gluteal injection should be made into the upper-outer quadrant of the gluteal area. **DO NOT ADMINISTER INTRAVENOUSLY.**

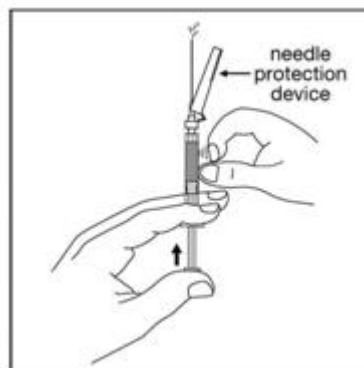

WARNING: To avoid a needle stick injury with a contaminated needle:

- Do not use free hand to press the Needle-Pro® safety device over the needle.

- Do not intentionally disengage the Needle-Pro® safety device.
- Do not attempt to straighten the needle or engage Needle-Pro® safety device if the needle is bent or damaged.
- Do not mishandle the Needle-Pro® safety device as it may cause the needle to protrude from the Needle-Pro® safety device.

17- After the injection is complete, press the needle into the orange Needle-Pro® safety device using a one-handed technique. Perform a one-handed technique by GENTLY pressing the orange Needle-Pro® safety device against a flat surface. AS THE ORANGE NEEDLE-PRO® SAFETY DEVICE IS PRESSED, THE NEEDLE WILL FIRMLY ENGAGE INTO THE ORANGE NEEDLE-PRO® SAFETY DEVICE. Visually confirm that the needle is fully engaged into the orange Needle-Pro® safety device before discarding. Discard needle appropriately. Also discard the other (unused) needle provided in the dose pack.

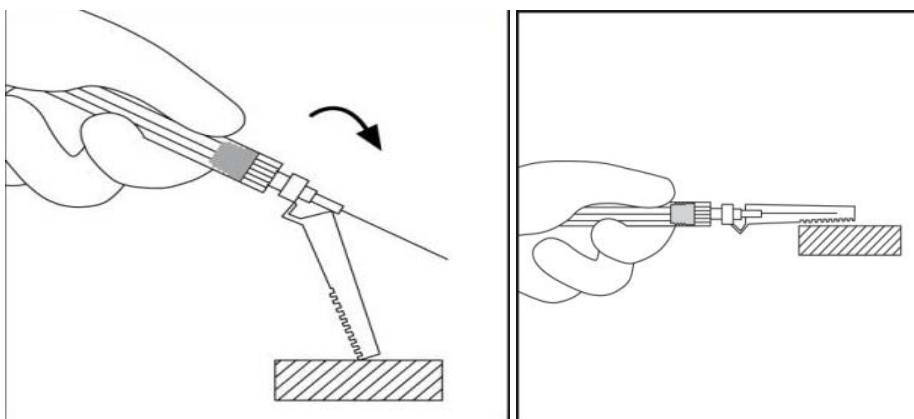

Stability after reconstitution: Once in suspension, the product may remain at room temperature (do not expose to temperatures above 77°F(25°C)). RISPERDAL CONSTA must be used within 6 hours of suspension, but should always be resuspended prior to administration if not used immediately

Parenteral drug products should be inspected visually for particulate matter and discoloration prior to administration, whenever solution and container permit.

Do Not Reuse: Medical devices require specific material characteristics to perform as intended. These characteristics have been verified for single use only. Any attempt to re-process the device for subsequent re-use may adversely affect the integrity of the device or lead to deterioration in performance.

3 DOSAGE FORMS AND STRENGTHS

RISPERDAL[®] CONSTA[®] is available in dosage strengths of 25 mg, 37.5 mg, and 50 mg risperidone. It is provided as a dose pack, consisting of a vial containing the risperidone microspheres, a pre filled syringe containing 2 mL of diluent for RISPERDAL[®] CONSTA[®], a SmartSite[®] Needle-Free Vial Access Device, and two Needle-Pro[®] safety needles for intramuscular injection (a 21 G UTW 1-inch needle with needle protection device for deltoid administration and a 20 G TW 2-inch needle with needle protection device for gluteal administration).

4 CONTRAINDICATIONS

RISPERDAL[®] CONSTA[®] (risperidone) is contraindicated in patients with a known hypersensitivity to the product.

5 WARNINGS AND PRECAUTIONS

5.1 Increased Mortality in Elderly Patients with Dementia-Related Psychosis

Elderly patients with dementia-related psychosis treated with antipsychotic drugs are at an increased risk of death. RISPERDAL[®] CONSTA[®] (risperidone) is not approved for the treatment of dementia-related psychosis (see Boxed Warning).

5.2 Cerebrovascular Adverse Events, Including Stroke, in Elderly Patients with Dementia-Related Psychosis

Cerebrovascular adverse events (e.g., stroke, transient ischemic attack), including fatalities, were reported in patients (mean age 85 years; range 73-97) in trials of oral risperidone in elderly patients with dementia related psychosis. In placebo-controlled trials, there was a significantly higher incidence of cerebrovascular adverse events in patients treated with oral risperidone compared to patients treated with placebo. RISPERDAL[®] CONSTA[®] is not approved for the treatment of patients with dementia related psychosis [See also Boxed Warning and Warnings and Precautions (5.1)]

5.3 Neuroleptic Malignant Syndrome (NMS)

A potentially fatal symptom complex sometimes referred to as Neuroleptic Malignant Syndrome (NMS) has been reported in association with antipsychotic drugs. Clinical manifestations of NMS are hyperpyrexia, muscle rigidity, altered mental status, and evidence of autonomic instability (irregular

pulse or blood pressure, tachycardia, diaphoresis, and cardiac dysrhythmia). Additional signs may include elevated creatine phosphokinase, myoglobinuria (rhabdomyolysis), and acute renal failure.

The diagnostic evaluation of patients with this syndrome is complicated. In arriving at a diagnosis, it is important to identify cases in which the clinical presentation includes both serious medical illness (e.g., pneumonia, systemic infection, etc.) and untreated or inadequately treated extrapyramidal signs and symptoms (EPS). Other important considerations in the differential diagnosis include central anticholinergic toxicity, heat stroke, drug fever, and primary central nervous system pathology.

The management of NMS should include: (1) immediate discontinuation of antipsychotic drugs and other drugs not essential to concurrent therapy; (2) intensive symptomatic treatment and medical monitoring; and (3) treatment of any concomitant serious medical problems for which specific treatments are available. There is no general agreement about specific pharmacological treatment regimens for uncomplicated NMS.

If a patient requires antipsychotic drug treatment after recovery from NMS, the potential reintroduction of drug therapy should be carefully considered. The patient should be carefully monitored, since recurrences of NMS have been reported.

5.4 Tardive Dyskinesia

A syndrome of potentially irreversible, involuntary, dyskinetic movements may develop in patients treated with antipsychotic drugs. Although the prevalence of the syndrome appears to be highest among the elderly, especially elderly women, it is impossible to rely upon prevalence estimates to predict, at the inception of antipsychotic treatment, which patients are likely to develop the syndrome. Whether antipsychotic drug products differ in their potential to cause tardive dyskinesia is unknown.

The risk of developing tardive dyskinesia and the likelihood that it will become irreversible are believed to increase as the duration of treatment and the total cumulative dose of antipsychotic drugs administered to the patient increase. However, the syndrome can develop, although much less commonly, after relatively brief treatment periods at low doses.

There is no known treatment for established cases of tardive dyskinesia, although the syndrome may remit, partially or completely, if antipsychotic treatment is withdrawn. Antipsychotic treatment, itself, however, may suppress (or partially suppress) the signs and symptoms of the syndrome and thereby may possibly mask the underlying process. The effect that symptomatic suppression has upon the long-term course of the syndrome is unknown.

Given these considerations, RISPERDAL[®] CONSTA[®] should be prescribed in a manner that is most likely to minimize the occurrence of tardive dyskinesia. Chronic antipsychotic treatment should generally be reserved for patients who suffer from a chronic illness that: (1) is known to respond to antipsychotic drugs, and (2) for whom alternative, equally effective, but potentially less harmful treatments are not available or appropriate. In patients who do require chronic treatment, the smallest dose and the shortest duration of treatment producing a satisfactory clinical response should be sought. The need for continued treatment should be reassessed periodically.

If signs and symptoms of tardive dyskinesia appear in a patient treated with RISPERDAL[®] CONSTA[®], drug discontinuation should be considered. However, some patients may require treatment with RISPERDAL[®] CONSTA[®] despite the presence of the syndrome.

5.5 Metabolic changes

Atypical antipsychotic drugs have been associated with metabolic changes that may increase cardiovascular/cerebrovascular risk. These metabolic changes include hyperglycemia, dyslipidemia, and body weight gain. While all the drugs in the class have been shown to produce some metabolic changes, each drug has its own specific risk profile

Hyperglycemia and Diabetes Mellitus

Hyperglycemia and diabetes mellitus, in some cases extreme and associated with ketoacidosis or hyperosmolar coma or death, has been reported in patients treated with atypical antipsychotics including RISPERDAL[®]. Assessment of the relationship between atypical antipsychotic use and glucose abnormalities is complicated by the possibility of an increased background risk of diabetes mellitus in patients with schizophrenia and the increasing incidence of diabetes mellitus in the general population. Given these confounders, the relationship between atypical antipsychotic use and hyperglycemia related adverse events is not completely understood. However, epidemiological studies suggest an increased risk of treatment-emergent hyperglycemia-related adverse events in patients treated with the atypical antipsychotics. Precise risk estimates for hyperglycemia-related adverse events in patients treated with atypical antipsychotics are not available.

Patients with an established diagnosis of diabetes mellitus who are started on atypical antipsychotics, including RISPERDAL, should be monitored regularly for worsening of glucose control. Patients with risk factors for diabetes mellitus (e.g., obesity, family history of diabetes) who are starting treatment with atypical antipsychotics, including RISPERDAL should undergo fasting blood glucose testing at the beginning of treatment and periodically during treatment. Any patient treated with atypical antipsychotics including RISPERDAL should be monitored for symptoms of hyperglycemia including polydipsia, polyuria, polyphagia, and weakness. Patients who develop symptoms of hyperglycemia during treatment with atypical antipsychotics including RISPERDAL, should undergo fasting blood glucose testing. In some cases, hyperglycemia has resolved when the atypical antipsychotic including RISPERDAL was discontinued; however, some patients required continuation of anti-diabetic treatment despite discontinuation of RISPERDAL.

Pooled data from 3 double-blind, placebo-controlled studies in subjects with schizophrenia and 4 double-blind, placebo-controlled monotherapy studies in subjects with bipolar mania with oral risperidone are presented in Table 1.

Table 1. Change in Random Glucose From Seven Placebo-Controlled, 3- to 8-Week, Fixed- or Flexible-Dose Studies in Adult Subjects With Schizophrenia or Bipolar Mania With Oral Risperidone

	Placebo	RISPERDAL [®]	
		1-8 mg/day	>8-16 mg/day
	n=555	n=748	n=164
Serum Glucose	-1.4	0.8	0.6
	Mean change from baseline (mg/dL)		
	0.6%	0.4%	0%
Serum Glucose (<140 mg/dL to ≥200 mg/dL)	(3/525)	(3/702)	(0/158)
	Proportion of patients with shifts		

In longer-term, controlled and uncontrolled studies in adult subjects, RISPERDAL[®] was associated with a mean change in glucose of +2.8 mg/dL at Week 24 (n=151) and +4.1 mg/dL at Week 48 (n=50)

Dyslipidemia

Undesirable alterations in lipids have been observed in patients treated with atypical antipsychotics

Pooled data from 7 placebo-controlled, 3- to 8-week, fixed- or flexible-dose studies in adult subjects with schizophrenia or bipolar mania are presented in Table 2.

Table 2. Change in Random Lipids From Seven Placebo-Controlled, 3- to 8-Week, Fixed- or Flexible-Dose Studies in Adult Subjects With Schizophrenia or Bipolar Mania With Oral Risperidone

	Placebo	RISPERDAL [®]	
		1-8 mg/day	>8-16 mg/day
Mean change from baseline (mg/dL)			
Cholesterol	n=559	n=742	n=156
Change from baseline	0.6	6.9	1.8
Triglycerides	n=183	n=307	n=123
Change from baseline	-17.4	-4.9	-8.3
Proportion of patients With Shifts			
Cholesterol	2.7%	4.3%	6.3%
(<200 mg/dL to ≥240 mg/dL)	(10/368)	(22/516)	(6/96)
Triglycerides	1.1%	2.7%	2.5%
(<500 mg/dL to ≥500 mg/dL)	(2/180)	(8/301)	(3/121)

In longer-term, controlled and uncontrolled studies, RISPERDAL[®] was associated with a mean change in (a) non-fasting cholesterol of +4.4 mg/dL at Week 24 (n=231) and +5.5 mg/dL at Week 48 (n=86); and (b) non-fasting triglycerides of +19.9 mg/dL at Week 24 (n=52)

Weight Gain

Weight gain has been observed with atypical antipsychotic use. Clinical monitoring of weight is recommended

Data from a placebo-controlled, 12-week, fixed-dose study in adult subjects with schizophrenia are presented in Table 3.

Table 3. Mean Change in Body Weight (kg) and the Proportion of Subjects With ≥7% Gain in Body Weight From a Placebo-Controlled, 12-Week, Fixed-Dose Study in Adult Subjects With Schizophrenia

	Placebo (n=83)	RISPERDAL [®] CONSTA [®]	
		25 mg (n=90)	50 mg (n=87)
Weight (kg)			
Change from baseline	-1.4	0.5	1.2
Weight Gain			
≥7% increase from baseline	6%	10%	8%

In an uncontrolled, longer-term, open-label study, RISPERDAL[®] CONSTA[®] was associated with a mean change in weight of +2.1 kg at Week 24 (n=268) and +2.8 kg at Week 50 (n=199)

5.6 Hyperprolactinemia

As with other drugs that antagonize dopamine D2 receptors, risperidone elevates prolactin levels and the elevation persists during chronic administration. Risperidone is associated with higher levels of prolactin elevation than other antipsychotic agents.

Hyperprolactinemia may suppress hypothalamic GnRH, resulting in reduced pituitary gonadotropin secretion. This, in turn, may inhibit reproductive function by impairing gonadal steroidogenesis in both female and male patients. Galactorrhea, amenorrhea, gynecomastia, and impotence have been reported in patients receiving prolactin-elevating compounds. Long-standing hyperprolactinemia when associated with hypogonadism may lead to decreased bone density in both female and male subjects.

Tissue culture experiments indicate that approximately one-third of human breast cancers are prolactin dependent *in vitro*, a factor of potential importance if the prescription of these drugs is contemplated in a patient with previously detected breast cancer. An increase in pituitary gland, mammary gland, and pancreatic islet cell neoplasia (mammary adenocarcinomas, pituitary and pancreatic adenomas) was observed in the risperidone carcinogenicity studies conducted in mice and rats [see *Nonclinical Toxicology* (13.1)]. Neither clinical studies nor epidemiologic studies conducted to date have shown an association between chronic administration of this class of drugs and tumorigenesis in humans; the available evidence is considered too limited to be conclusive at this time.

5.7 Orthostatic Hypotension

RISPERDAL[®] CONSTA[®] may induce orthostatic hypotension associated with dizziness, tachycardia, and in some patients, syncope, especially during the initial dose-titration period with oral risperidone, probably reflecting its alpha adrenergic antagonistic properties. Syncope was reported in 0.8% (12/1499 patients) of patients treated with RISPERDAL[®] CONSTA[®] in multiple-dose studies. Patients should be instructed in nonpharmacologic interventions that help to reduce the occurrence of orthostatic hypotension (e.g., sitting on the edge of the bed for several minutes before attempting to stand in the morning and slowly rising from a seated position).

RISPERDAL[®] CONSTA[®] should be used with particular caution in (1) patients with known cardiovascular disease (history of myocardial infarction or ischemia, heart failure, or conduction abnormalities), cerebrovascular disease, and conditions which would predispose patients to hypotension, e.g., dehydration and hypovolemia, and (2) in the elderly and patients with renal or hepatic impairment. Monitoring of orthostatic vital signs should be considered in all such patients, and a dose reduction should be considered if hypotension occurs. Clinically significant hypotension has been observed with concomitant use of oral RISPERDAL[®] and antihypertensive medication.

5.8 Leukopenia, Neutropenia, and Agranulocytosis

Class Effect: In clinical trial and/or postmarketing experience, events of leukopenia/neutropenia have been reported temporally related to antipsychotic agents, including RISPERDAL[®] CONSTA[®]. Agranulocytosis has also been reported.

Possible risk factors for leukopenia/neutropenia include pre-existing low white blood cell count (WBC) and a history of drug-induced leukopenia/neutropenia. Patients with a history of a clinically significant low WBC or a drug-induced leukopenia/neutropenia should have their complete blood count (CBC) monitored frequently during the first few months of therapy and discontinuation of RISPERDAL[®] CONSTA[®] should be considered at the first sign of a clinically significant decline in WBC in the absence of other causative factors.

Patients with clinically significant neutropenia should be carefully monitored for fever or other symptoms or signs of infection and treated promptly if such symptoms or signs occur. Patients with severe neutropenia (absolute neutrophil count <1000/mm³) should discontinue RISPERDAL[®] CONSTA[®] and have their WBC followed until recovery.

5.9 Potential for Cognitive and Motor Impairment

Somnolence was reported by 5% of patients treated with RISPERDAL[®] CONSTA[®] in multiple-dose trials. Since risperidone has the potential to impair judgment, thinking, or motor skills, patients should be cautioned about operating hazardous machinery, including automobiles, until they are reasonably certain that treatment with RISPERDAL[®] CONSTA[®] does not affect them adversely.

5.10 Seizures

During premarketing testing, seizures occurred in 0.3% (5/1499 patients) of patients treated with RISPERDAL[®] CONSTA[®]. Therefore, RISPERDAL[®] CONSTA[®] should be used cautiously in patients with a history of seizures.

5.11 Dysphagia

Esophageal dysmotility and aspiration have been associated with antipsychotic drug use. Aspiration pneumonia is a common cause of morbidity and mortality in patients with advanced Alzheimer's dementia. RISPERDAL[®] CONSTA[®] and other antipsychotic drugs should be used cautiously in patients at risk for aspiration pneumonia. *[see also Boxed Warning and Warnings and Precautions (5.1)]*

5.12 Priapism

Priapism has been reported during postmarketing surveillance *[see Adverse Reactions (6.9)]* Severe priapism may require surgical intervention.

5.13 Thrombotic Thrombocytopenic Purpura (TTP)

A single case of TTP was reported in a 28 year-old female patient receiving oral RISPERDAL[®] in a large, open premarketing experience (approximately 1300 patients). She experienced jaundice, fever, and bruising, but eventually recovered after receiving plasmapheresis. The relationship to RISPERDAL[®] therapy is unknown.

5.14 Body Temperature Regulation

Disruption of body temperature regulation has been attributed to antipsychotic agents. Both hyperthermia and hypothermia have been reported in association with oral RISPERDAL[®] or RISPERDAL[®] CONSTA[®] use. Caution is advised when prescribing RISPERDAL[®] CONSTA[®] for patients who will be exposed to temperature extremes.

5.15 Administration

RISPERDAL[®] CONSTA[®] should be injected into the deltoid or gluteal muscle, and care must be taken to avoid inadvertent injection into a blood vessel. [see *Dosage and Administration (2)* and *Adverse Reactions (6.7)*]

5.16 Antiemetic Effect

Risperidone has an antiemetic effect in animals; this effect may also occur in humans, and may mask signs and symptoms of overdose with certain drugs or of conditions such as intestinal obstruction, Reye's syndrome, and brain tumor.

5.17 Suicide

There is an increased risk of suicide attempt in patients with schizophrenia or bipolar disorder, and close supervision of high risk patients should accompany drug therapy. RISPERDAL[®] CONSTA[®] is to be administered by a health care professional [see *Dosage and Administration (2)*]; therefore, suicide due to an overdose is unlikely.

5.18 Use in Patients with Concomitant Illness

Clinical experience with RISPERDAL[®] CONSTA[®] in patients with certain concomitant systemic illnesses is limited. Patients with Parkinson's Disease or Dementia with Lewy Bodies who receive antipsychotics, including RISPERDAL[®] CONSTA[®], are reported to have an increased sensitivity to antipsychotic medications. Manifestations of this increased sensitivity have been reported to include confusion, obtundation, postural instability with frequent falls, extrapyramidal symptoms, and clinical features consistent with the neuroleptic malignant syndrome.

Caution is advisable when using RISPERDAL[®] CONSTA[®] in patients with diseases or conditions that could affect metabolism or hemodynamic responses. RISPERDAL[®] CONSTA[®] has not been evaluated or used to any appreciable extent in patients with a recent history of myocardial infarction or unstable heart disease. Patients with these diagnoses were excluded from clinical studies during the product's premarket testing.

Increased plasma concentrations of risperidone and 9-hydroxyrisperidone occur in patients with severe renal impairment (creatinine clearance <30 mL/min/1.73 m²) treated with oral RISPERDAL[®]; an increase in the free fraction of risperidone is also seen in patients with severe hepatic impairment. Patients with renal or hepatic impairment should be carefully titrated on oral RISPERDAL[®] before treatment with RISPERDAL[®] CONSTA[®] is initiated at a dose of 25 mg. A lower initial dose of 12.5 mg may be appropriate when clinical factors warrant dose adjustment, such as in patients with renal or hepatic impairment [see *Dosage and Administration (2.4)*].

5.19 *Intraoperative Floppy Iris Syndrome*ⁱ

Intraoperative Floppy Iris Syndrome (IFIS) has been observed during cataract surgery in patients treated with medicines with alpha1-adrenergic antagonist effect, including RISPERDAL[®] CONSTA[®] (see Section 4.8).

IFIS may increase the risk of eye complications during and after the operation. Current or past use of medicines with alpha1-adrenergic antagonist effect should be made known to the ophthalmic surgeon in advance of surgery. The potential benefit of stopping alpha1 blocking therapy prior to cataract surgery has not been established and must be weighed against the risk of stopping the antipsychotic therapy.

5.19 Osteodystrophy and Tumors in Animals

RISPERDAL[®] CONSTA[®] produced osteodystrophy in male and female rats in a 1 year toxicity study and a 2-year carcinogenicity study at a dose of 40 mg/kg administered IM every 2 weeks.

RISPERDAL[®] CONSTA[®] produced renal tubular tumors (adenoma, adenocarcinoma) and adrenomedullary pheochromocytomas in male rats in the 2-year carcinogenicity study at 40 mg/kg administered IM every 2 weeks. In addition, RISPERDAL[®] CONSTA[®] produced an increase in a marker of cellular proliferation in renal tissue in males in the 1-year toxicity study and in renal tumor-bearing males in the 2-year carcinogenicity study at 40 mg/kg administered IM every 2 weeks. (Cellular proliferation was not measured at the low dose or in females in either study.)

The effect dose for osteodystrophy and the tumor findings is 8 times the IM maximum recommended human dose (MRHD) (50 mg) on a mg/m² basis and is associated with a plasma exposure (AUC) 2 times the expected plasma exposure (AUC) at the IM MRHD. The no-effect dose for these findings was 5 mg/kg (equal to the IM MRHD on a mg/m² basis). Plasma exposure (AUC) at the no-effect dose was one third the expected plasma exposure (AUC) at the IM MRHD.

Neither the renal or adrenal tumors, nor osteodystrophy, were seen in studies of orally administered risperidone. Osteodystrophy was not observed in dogs at doses up to 14 times (based on AUC) the IM MRHD in a 1 year toxicity study.

The renal tubular and adrenomedullary tumors in male rats and other tumor findings are described in more detail in Section 13.1 (Carcinogenicity, Mutagenesis, Impairment of Fertility).

The relevance of these findings to human risk is unknown.

5.20 Monitoring: Laboratory Tests

No specific laboratory tests are recommended.

6 ADVERSE REACTIONS

The following are discussed in more detail in other sections of the labeling:

- Increased mortality in elderly patients with dementia-related psychosis [*see **Boxed Warning and Warnings and Precaution (5.1)***]
- Cerebrovascular adverse events, including stroke, in elderly patients with dementia-related psychosis [*see **Warnings and Precautions (5.2)***]
- Neuroleptic malignant syndrome [*see **Warnings and Precautions (5.3)***]
- Tardive dyskinesia [*see **Warnings and Precautions (5.4)***]
- Metabolic changes {*see **Warnings and Precautions (5.5)***}
- Hyperprolactinemia [*see **Warnings and Precautions (5.6)***]
- Orthostatic hypotension [*see **Warnings and Precautions (5.7)***]
- Leukopenia/Neutropenia and Agranulocytosis [*see **Warnings and Precautions (5.8)***]
- Potential for cognitive and motor impairment [*see **Warnings and Precautions (5.9)***]

- Seizures [see Warnings and Precautions (5.10)]
- Dysphagia [see Warnings and Precautions (5.11)]
- Priapism [see Warnings and Precautions (5.12)]
- Thrombotic Thrombocytopenic Purpura (TTP) [see Warnings and Precautions (5.13)]
- Disruption of body temperature regulation [see Warnings and Precautions (5.14)]
- Avoidance of inadvertent injection into a blood vessel [see Warnings and Precautions (5.15)]
- Antiemetic effect [see Warnings and Precautions (5.16)]
- Suicide [see Warnings and Precautions (5.17)]
- Increased sensitivity in patients with Parkinson's disease or those with dementia with Lewy bodies [see Warnings and Precautions (5.18)]
- Diseases or conditions that could affect metabolism or hemodynamic responses [see Warnings and Precautions (5.18)]
- Osteodystrophy and tumors in animals [see Warnings and Precautions (5.19)]

The most common adverse reactions in clinical trials in patients with schizophrenia ($\geq 5\%$) were: headache, parkinsonism, dizziness, akathisia, fatigue, constipation, dyspepsia, sedation, weight increased, pain in extremity, and dry mouth. The most common adverse reactions in the double-blind, placebo-controlled periods of the bipolar disorder trials were weight increased (5% in the monotherapy trial) and tremor and parkinsonism ($\geq 10\%$ in the adjunctive treatment trial).

The most common adverse reactions that were associated with discontinuation from the 12 week double-blind, placebo-controlled trial in patients with schizophrenia (causing discontinuation in $\geq 1\%$ of patients) were agitation, depression, anxiety, and akathisia. Adverse reactions that were associated with discontinuation from the double-blind, placebo-controlled periods of the bipolar disorder trials were hyperglycemia (one patient in the monotherapy trial) and hypokinesia and tardive dyskinesia (one patient each in the adjunctive treatment trial).

The data described in this section are derived from a clinical trial database consisting of 2392 patients exposed to one or more doses of RISPERDAL[®] CONSTA[®] for the treatment of schizophrenia. Of these 2392 patients, 332 were patients who received RISPERDAL[®] CONSTA[®] while participating in a 12-week double-blind, placebo-controlled trial. Two hundred two (202) of the 332 were schizophrenia patients who received 25 mg or 50 mg RISPERDAL[®] CONSTA[®]. The conditions and duration of treatment with RISPERDAL[®] CONSTA[®] in the other clinical trials varied greatly and included (in overlapping categories) double blind, fixed- and flexible-dose, placebo- or active-controlled studies and open-label phases of studies, inpatients and outpatients, and short-term (up to 12 weeks) and longer term (up to 4 years) exposures. Safety was assessed by collecting adverse events and performing physical examinations, vital signs, body weights, laboratory analyses, and ECGs.

In addition to the studies in patients with schizophrenia, safety data are presented from a trial assessing the efficacy and safety of RISPERDAL[®] CONSTA[®] when administered as monotherapy for maintenance treatment in patients with bipolar I disorder. The subjects in this multi-center, double-blind, placebo-controlled study were adult patients who met DSM-IV criteria for Bipolar Disorder Type I and who were stable on risperidone (oral or long-acting injection), were stable on other antipsychotics or mood stabilizers, or were experiencing an acute episode. After a 3-week period of treatment with open-label oral risperidone (n=440), subjects who demonstrated an initial response to oral risperidone in this period

and those who were stable on risperidone (oral or long-acting injection) at study entry entered into a 26-week stabilization period of open-label RISPERDAL[®] CONSTA[®] (n=501). Subjects who demonstrated a maintained response during this period were then randomized into a 24-month double-blind, placebo-controlled period in which they received RISPERDAL[®] CONSTA[®] (n=154) or placebo (n=149) as monotherapy. Subjects who relapsed or who completed the double-blind period could choose to enter an 8-week open-label RISPERDAL[®] CONSTA[®] extension period (n=160).

Safety data are also presented from a trial assessing the efficacy and safety of RISPERDAL[®] CONSTA[®] when administered as adjunctive maintenance treatment in patients with bipolar disorder. The subjects in this multi-center, double-blind, placebo-controlled study were adult patients who met DSM-IV criteria for Bipolar Disorder Type I or Type II and who experienced at least 4 episodes of mood disorder requiring psychiatric/clinical intervention in the previous 12 months, including at least 2 episodes in the 6 months prior to the start of the study. At the start of this study, all patients (n=275) entered into a 16-week open-label treatment phase in which they received RISPERDAL[®] CONSTA[®] in addition to continuing their treatment as usual, which consisted of various mood stabilizers (primarily lithium and valproate), antidepressants, and/or anxiolytics. Patients who reached remission at the end of this 16-week open-label treatment phase (n=139) were then randomized into a 52-week double-blind, placebo-controlled phase in which they received RISPERDAL[®] CONSTA[®] (n=72) or placebo (n = 67) as adjunctive treatment in addition to continuing their treatment as usual. Patients who did not reach remission at the end of the 16-week open-label treatment phase could choose to continue to receive RISPERDAL[®] CONSTA[®] as adjunctive therapy in an open-label manner, in addition to continuing their treatment as usual, for up to an additional 36 weeks as clinically indicated for a total period of up to 52 weeks; these patients (n=70) were also included in the evaluation of safety.

Adverse events during exposure to study treatment were obtained by general inquiry and recorded by clinical investigators using their own terminology. Consequently, to provide a meaningful estimate of the proportion of individuals experiencing adverse events, events were grouped in standardized categories using MedDRA terminology.

Throughout this section, adverse reactions are reported. Adverse reactions are adverse events that were considered to be reasonably associated with the use of RISPERDAL[®] CONSTA[®] (adverse drug reactions) based on the comprehensive assessment of the available adverse event information. A causal association for RISPERDAL[®] CONSTA[®] often cannot be reliably established in individual cases. Further, because clinical trials are conducted under widely varying conditions, adverse reaction rates observed in the clinical trials of a drug cannot be directly compared to rates in the clinical trials of another drug and may not reflect the rates observed in clinical practice.

The majority of all adverse reactions were mild to moderate in severity.

6.1 Commonly-Observed Adverse Reactions in Double-Blind, Placebo-Controlled Clinical Trials

Table 4 lists the adverse reactions reported in 2% or more of RISPERDAL[®] CONSTA[®]-treated patients with schizophrenia in one 12-week double-blind, placebo-controlled trial.

Table 4. Adverse Reactions in \geq 2% of RISPERDAL[®] CONSTA[®]-Treated Patients with Schizophrenia in a 12-Week Double-Blind, Placebo-Controlled Trial

Percentage of Patients Reporting Event

System Organ Class Adverse Reaction	RISPERDAL [®] CONSTA [®]		Placebo (N=98)
	25 mg (N=99)	50 mg (N=103)	
Eye disorders			
Vision blurred	2	3	0
Gastrointestinal disorders			
Constipation	5	7	1
Dry mouth	0	7	1
Dyspepsia	6	6	0
Nausea	3	4	5
Toothache	1	3	0
Salivary hypersecretion	4	1	0
General disorders and administration site conditions			
Fatigue*	3	9	0
Edema peripheral	2	3	1
Pain	4	1	0
Pyrexia	2	1	0
Infections and infestations			
Upper respiratory tract infection	2	0	1
Investigations			
Weight increased	5	4	2
Weight decreased	4	1	1
Musculoskeletal and connective tissue disorders			
Pain in extremity	6	2	1
Nervous system disorders			
Headache	15	21	12
Parkinsonism*	8	15	9
Dizziness	7	11	6
Akathisia*	4	11	6
Sedation*	5	6	3
Tremor	0	3	0
Syncope	2	1	0
Hypoesthesia	2	0	0
Respiratory, thoracic and mediastinal disorders			
Cough	4	2	3
Sinus congestion	2	0	0
Skin and subcutaneous tissue disorders			
Acne	2	2	0
Dry skin	2	0	0

* Fatigue includes fatigue and asthenia. Parkinsonism includes extrapyramidal disorder, musculoskeletal stiffness, muscle rigidity, and bradykinesia. Akathisia includes akathisia and restlessness. Sedation includes sedation and somnolence.

6.2 Commonly-Observed Adverse Reactions in Double-Blind, Placebo-Controlled Clinical Trials – Bipolar Disorder

Table 5 lists the treatment-emergent adverse reactions reported in 2% or more of RISPERDAL[®] CONSTA[®]-treated patients in the 24-month-double-blind, placebo-controlled treatment period of the trial assessing the efficacy and safety of RISPERDAL[®] CONSTA[®] when administered as monotherapy for maintenance treatment in patients with Bipolar I Disorder.

Table 5. Adverse Reactions in $\geq 2\%$ of Patients with Bipolar I Disorder Treated with RISPERDAL[®] CONSTA[®] as Monotherapy in a 24-Month Double-Blind, Placebo-Controlled Trial

System/Organ Class	Percentage of Patients Reporting Event	
	RISPERDAL [®] CONSTA [®] (N=154)	Placebo (N=149)
Adverse Reaction		
Investigations		
Weight increased	5	1
Nervous system disorders		
Dizziness	3	1
Vascular disorders		
Hypertension	3	1

Table 6 lists the treatment-emergent adverse reactions reported in 4% or more of patients in the 52-week double-blind, placebo-controlled treatment phase of a trial assessing the efficacy and safety of RISPERDAL[®] CONSTA[®] when administered as adjunctive maintenance treatment in patients with bipolar disorder.

Table 6. Adverse Reactions in $\geq 4\%$ of Patients with Bipolar Disorder Treated with RISPERDAL[®] CONSTA[®] as Adjunctive Therapy in a 52-Week Double-Blind, Placebo-Controlled Trial

System/Organ Class	Percentage of Patients Reporting Event	
	RISPERDAL [®] CONSTA [®] Treatment as Usual ^a . (N=72)	Placebo Treatment as Usual ^a . (N=67)
Adverse Reaction		
General disorders and administration site conditions		
Gait abnormal	4	0
Infections and infestations		
Upper respiratory tract infection	6	3
Investigations		
Weight increased	7	1
Metabolism and nutrition disorders		
Decreased appetite	6	1
Increased appetite	4	0
Musculoskeletal and connective tissue disorders		

Arthralgia	4	3
Nervous system disorders		
Tremor	24	16
Parkinsonism ^b .	15	6
Dyskinesia ^b .	6	3
Sedation ^c .	7	1
Disturbance in attention	4	0
Reproductive system and breast disorders		
Amenorrhea	4	1
Respiratory, thoracic and mediastinal disorders		
Cough	4	1

^a Patients received double-blind RISPERDAL® CONSTA® or placebo in addition to continuing their treatment as usual, which included mood stabilizers, antidepressants, and/or anxiolytics.

^b Parkinsonism includes muscle rigidity, hypokinesia, cogwheel rigidity, and bradykinesia. Dyskinesia includes muscle twitching and dyskinesia

^c Sedation includes sedation and somnolence.

6.3 Other Adverse Reactions Observed During the Clinical Trial Evaluation of RISPERIDONE

The following additional adverse reactions occurred in <2% of the RISPERDAL® CONSTA®-treated patients in the above schizophrenia double-blind, placebo-controlled trial dataset, in <2% of the RISPERDAL® CONSTA®-treated patients in the above double-blind, placebo-controlled period of the monotherapy bipolar disorder trial dataset, or in <4% of the RISPERDAL® CONSTA®-treated patients in the above double-blind, placebo-controlled period of the adjunctive treatment bipolar disorder trial dataset. The following also includes additional adverse reactions reported at any frequency in RISPERDAL® CONSTA®-treated patients who participated in the open-label phases of the above bipolar disorder studies and in other studies, including double-blind, active controlled and open-label studies in schizophrenia and bipolar disorder.

Blood and lymphatic system disorders: anemia, neutropenia

Cardiac disorders: tachycardia, atrioventricular block first degree, palpitations, sinus bradycardia, bundle branch block left, bradycardia, sinus tachycardia, bundle branch block right

Ear and labyrinth disorders: ear pain, vertigo

Endocrine disorders: hyperprolactinemia

Eye disorders: conjunctivitis, visual acuity reduced

Gastrointestinal disorders: diarrhea, vomiting, abdominal pain upper, abdominal pain, stomach discomfort, gastritis

General disorders and administration site conditions: injection site pain, chest discomfort, chest pain, influenza like illness, sluggishness, malaise, induration, injection site induration, injection site swelling, injection site reaction, face edema

Immune system disorders: hypersensitivity

Infections and infestations: nasopharyngitis, influenza, bronchitis, urinary tract infection, rhinitis, respiratory tract infection, ear infection, pneumonia, lower respiratory tract infection, pharyngitis, sinusitis, viral infection, infection, localized infection, cystitis, gastroenteritis, subcutaneous abscess

Injury and poisoning: fall, procedural pain

Investigations: blood prolactin increased, alanine aminotransferase increased, electrocardiogram abnormal, gamma-glutamyl transferase increased, blood glucose increased, hepatic enzyme increased, aspartate aminotransferase increased, electrocardiogram QT prolonged, glucose urine present

Metabolism and nutritional disorders: anorexia, hyperglycemia

Musculoskeletal, connective tissue and bone disorders: posture abnormal, myalgia, back pain, buttock pain, muscular weakness, neck pain, musculoskeletal chest pain

Nervous system disorders: coordination abnormal, dystonia, tardive dyskinesia, drooling, paresthesia, dizziness postural, convulsion, akinesia, hypokinesia, dysarthria

Psychiatric disorders: insomnia, agitation, anxiety, sleep disorder, depression, initial insomnia, libido decreased, nervousness

Renal and urinary disorders: urinary incontinence

Reproductive system and breast disorders: galactorrhea, oligomenorrhea, erectile dysfunction, sexual dysfunction, ejaculation disorder, gynecomastia, breast discomfort, menstruation irregular, menstruation delayed, menstrual disorder, ejaculation_delayed

Respiratory, thoracic and mediastinal disorders: nasal congestion, pharyngolaryngeal pain, dyspnea, rhinorrhea

Skin and subcutaneous tissue disorders: rash, eczema, pruritis generalized, pruritus

Vascular disorders: hypotension, orthostatic hypotension

Adverse Reactions Reported with Oral RISPERDAL®

The following is a list of additional adverse reactions that have been reported during the clinical trial evaluation of oral RISPERDAL®, regardless of frequency of occurrence:

Blood and Lymphatic Disorders: granulocytopenia

Cardiac Disorders: atrioventricular block

Ear and Labyrinth Disorders: tinnitus

Eye Disorders: ocular hyperemia, eye discharge, eye rolling, eyelid edema, eye swelling, eyelid margin crusting, dry eye, lacrimation increased, photophobia, glaucoma

Gastrointestinal Disorders: abdominal pain upper, dysphagia, fecaloma, abdominal discomfort, fecal incontinence, lip swelling, cheilitis, apyhalism

General Disorders: thirst, feeling abnormal, gait disturbance, pitting edema, edema, chills, discomfort, generalized edema, drug withdrawal syndrome, peripheral coldness

Immune System Disorders: drug hypersensitivity

Infections and Infestations: tonsillitis, eye infection, cellulitis, otitis media, onychomycosis, acarodermatitis, bronchopneumonia, respiratory tract infection, tracheobronchitis, otitis media chronic

Investigations: body temperature increased, heart rate increased, eosinophil count increased, white blood cell count decreased, hemoglobin decreased, blood creatine phosphokinase increased, hematocrit decreased, body temperature decreased, blood pressure decreased, transaminases increased

Metabolism and Nutrition Disorders: polydipsia

Musculoskeletal, Connective Tissue, and Bone Disorders: joint swelling, joint stiffness, rhabdomyolysis, torticollis

Nervous System Disorders: hypertonia, balance disorder, dysarthria, unresponsive to stimuli, depressed level of consciousness, movement disorder, hypokinesia, parkinsonian rest tremor, transient ischemic attack, cerebrovascular accident, masked facies, speech disorder, loss of consciousness, muscle contractions involuntary, akinesia, cerebral ischemia, cerebrovascular disorder, neuroleptic malignant syndrome, diabetic coma, head titubation

Psychiatric Disorders: blunted affect, confusional state, middle insomnia, listlessness, anorgasmia

Renal and Urinary Disorders: enuresis, dysuria, pollakiuria

Reproductive System and Breast Disorders: vaginal discharge, retrograde ejaculation, ejaculation disorder, ejaculation failure, breast enlargement

Respiratory, Thoracic, and Mediastinal Disorders: epistaxis, wheezing, pneumonia aspiration, dysphonia, productive cough, pulmonary congestion, respiratory tract congestion, rales, respiratory disorder, hyperventilation, nasal edema

Skin and Subcutaneous Tissue Disorders: erythema, skin discoloration, skin lesion, skin disorder, rash erythematous, rash papular, hyperkeratosis, dandruff, seborrheic dermatitis, rash generalised, rash maculopapular

Vascular Disorders: flushing

6.4 Discontinuations Due to Adverse Reactions

Schizophrenia

Approximately 11% (22/202) of RISPERDAL[®] CONSTA[®]-treated patients in the 12-week double-blind, placebo-controlled schizophrenia trial discontinued treatment due to an adverse event, compared with 13% (13/98) who received placebo. The adverse reactions associated with discontinuation in two or more RISPERDAL[®] CONSTA[®]-treated patients were: agitation (3%), depression (2%), anxiety (1%), and akathisia (1%).

Bipolar Disorder

In the 24-month double-blind, placebo-controlled treatment period of the trial assessing the efficacy and safety of RISPERDAL[®] CONSTA[®] when administered as monotherapy for maintenance treatment in patients with bipolar I disorder, 1 (0.6%) of 154 RISPERDAL[®] CONSTA[®]-treated patients discontinued due to an adverse reaction (hyperglycemia).

In the 52-week double-blind phase of the placebo-controlled trial in which RISPERDAL[®] CONSTA[®] was administered as adjunctive therapy to patients with bipolar disorder in addition to continuing with their treatment as usual, approximately 4% (3/72) of RISPERDAL[®] CONSTA[®]-treated patients discontinued treatment due to an adverse event, compared with 1.5% (1/67) of placebo-treated patients. Adverse reactions associated with discontinuation in RISPERDAL[®] CONSTA[®]-treated patients were: hypokinesia (one patient) and tardive dyskinesia (one patient).

6.5 Dose Dependency of Adverse Reactions in Clinical Trials

Extrapyramidal Symptoms:

Two methods were used to measure extrapyramidal symptoms (EPS) in the 12-week double-blind, placebo controlled trial comparing three doses of RISPERDAL[®] CONSTA[®] (25 mg, 50 mg, and 75 mg) with placebo in patients with schizophrenia, including: (1) the incidence of spontaneous reports of EPS symptoms; and (2) the change from baseline to endpoint on the total score (sum of the subscale scores for parkinsonism, dystonia, and dyskinesia) of the Extrapyramidal Symptom Rating Scale (ESRS).

As shown in Table 1, the overall incidence of EPS-related adverse reactions (akathisia, dystonia, parkinsonism, and tremor) in patients treated with 25 mg RISPERDAL[®] CONSTA[®] was comparable to that of patients treated with placebo; the incidence of EPS related adverse reactions was higher in patients treated with 50 mg RISPERDAL[®] CONSTA[®].

The median change from baseline to endpoint in total ESRS score showed no worsening in patients treated with RISPERDAL[®] CONSTA[®] compared with patients treated with placebo: 0 (placebo group);

-1 (25 mg group, significantly less than the placebo group); and 0 (50 mg group).

Dystonia

Class Effect: Symptoms of dystonia, prolonged abnormal contractions of muscle groups, may occur in susceptible individuals during the first few days of treatment. Dystonic symptoms include: spasm of the neck muscles, sometimes progressing to tightness of the throat, swallowing difficulty, difficulty breathing, and/or protrusion of the tongue. While these symptoms can occur at low doses, they occur more frequently and with greater severity with high potency and at higher doses of first generation antipsychotic drugs. An elevated risk of acute dystonia is observed in males and younger age groups.

6.6 Changes in ECG

The electrocardiograms of 202 schizophrenic patients treated with 25 mg or 50 mg RISPERDAL[®] CONSTA[®] and 98 schizophrenic patients treated with placebo in the 12 week double blind, placebo controlled trial were evaluated. Compared with placebo, there were no statistically significant differences in QTc intervals (using Fridericia's and linear correction factors) during treatment with RISPERDAL[®] CONSTA[®].

The electrocardiograms of 227 patients with Bipolar I Disorder were evaluated in the 24-month double-blind, placebo-controlled period. There were no clinically relevant differences in QTc intervals (using Fridericia's and linear correction factors) during treatment with RISPERDAL[®] CONSTA[®] compared to placebo.

The electrocardiograms of 85 patients with bipolar disorder were evaluated in the 52-week double-blind, placebo-controlled trial. There were no statistically significant differences in QTc intervals (using Fridericia's and linear correction factors) during treatment with RISPERDAL[®] CONSTA[®] 25 mg, 37.5 mg, or 50 mg when administered as adjunctive treatment in addition to continuing treatment as usual compared to placebo.

6.7 Pain Assessment and Local Injection Site Reactions

The mean intensity of injection pain reported by patients with schizophrenia using a visual analog scale (0 = no pain to 100 = unbearably painful) decreased in all treatment groups from the first to the last injection (placebo: 16.7 to 12.6; 25 mg: 12.0 to 9.0; 50 mg: 18.2 to 11.8). After the sixth injection (Week 10), investigator ratings indicated that 1% of patients treated with 25 mg or 50 mg RISPERDAL[®] CONSTA[®] experienced redness, swelling, or induration at the injection site.

In a separate study to observe local-site tolerability in which RISPERDAL[®] CONSTA[®] was administered into the deltoid muscle every 2 weeks over a period of 8 weeks, no patient discontinued treatment due to local injection site pain or reaction. Clinician ratings indicated that only mild redness, swelling, or induration at the injection site was observed in subjects treated with 37.5 mg or 50 mg RISPERDAL[®] CONSTA[®] at 2 hours after deltoid injection. All ratings returned to baseline at the predose assessment of the next injection 2 weeks later. No moderate or severe reactions were observed in any subject.

6.8 Postmarketing Experience

The following adverse reactions have been identified during postapproval use of risperidone; because these reactions are reported voluntarily from a population of uncertain size, it is not possible to reliably estimate their frequency: agranulocytosis, alopecia, anaphylactic reaction, angioedema, atrial fibrillation,

blood cholesterol increased, blood triglycerides increased, diabetes mellitus, diabetic ketoacidosis in patients with impaired glucose metabolism, drug withdrawal syndrome neonatal, dysgeusia, hypoglycemia, hypothermia, inappropriate antidiuretic hormone secretion, intestinal obstruction, jaundice, mania, pancreatitis, priapism, QT prolongation, sleep apnea syndrome, thrombocytopenia, urinary retention, water intoxication, Floppy iris syndrome (intraoperative) and ileus. In addition, the following adverse reactions have been observed during postapproval use of RISPERDAL[®] CONSTA[®]: cerebrovascular disorders, including cerebrovascular accidents, and diabetes mellitus aggravated.

Retinal artery occlusion after injection of RISPERDAL[®] CONSTA[®] has been reported during postmarketing surveillance. This has been reported in the presence of abnormal arteriovenous anastomosis.

Serious injection site reactions including abscess, cellulitis, cyst, hematoma, necrosis, nodule, and ulcer have been reported with RISPERDAL[®] CONSTA[®] during postmarketing surveillance. Isolated cases required surgical intervention

Very rarely, cases of anaphylactic reaction after injection with RISPERDAL[®] CONSTA[®] have been reported during postmarketing experience in patients who have previously tolerated oral risperidone.ⁱⁱ

7 DRUG INTERACTIONS

The interactions of RISPERDAL[®] CONSTA[®] with coadministration of other drugs have not been systematically evaluated. The drug interaction data provided in this section is based on studies with oral RISPERDAL[®].

7.1 Centrally-Acting Drugs and Alcohol

Given the primary CNS effects of risperidone, caution should be used when RISPERDAL[®] CONSTA[®] is administered in combination with other centrally acting drugs or alcohol.

7.2 Drugs with Hypotensive Effects

Because of its potential for inducing hypotension, RISPERDAL[®] CONSTA[®] may enhance the hypotensive effects of other therapeutic agents with this potential.

7.3 Levodopa and Dopamine Agonists

RISPERDAL[®] CONSTA[®] may antagonize the effects of levodopa and dopamine agonists.

7.4 Amitriptyline

Amitriptyline did not affect the pharmacokinetics of risperidone or of risperidone and 9-hydroxyrisperidone combined following concomitant administration with oral RISPERDAL[®].

7.5 Cimetidine and Ranitidine

Cimetidine and ranitidine increased the bioavailability of oral risperidone by 64% and 26%, respectively. However, cimetidine did not affect the AUC of risperidone and 9-hydroxyrisperidone combined, whereas ranitidine increased the AUC of risperidone and 9-hydroxyrisperidone combined by 20%.

7.6 Clozapine

Chronic administration of clozapine with risperidone may decrease the clearance of risperidone.

7.7 Lithium

Repeated doses of oral RISPERDAL[®] (3 mg twice daily) did not affect the exposure (AUC) or peak plasma concentrations (C_{max}) of lithium (n=13).

7.8 Valproate

Repeated doses of oral RISPERDAL[®] (4 mg once daily) did not affect the pre-dose or average plasma concentrations and exposure (AUC) of valproate (1000 mg/day in three divided doses) compared to placebo (n=21). However, there was a 20% increase in valproate peak plasma concentration (C_{max}) after concomitant administration of oral RISPERDAL[®].

7.9 Digoxin

Oral RISPERDAL[®] (0.25 mg twice daily) did not show a clinically relevant effect on the pharmacokinetics of digoxin.

7.10 Topiramate

Oral RISPERDAL[®] administered at doses from 1-6 mg/day concomitantly with topiramate 400 mg/day resulted in a 23% decrease in risperidone C_{max} and a 33% decrease in risperidone AUC₀₋₁₂ hour at steady state. Minimal reductions in the exposure to risperidone and 9-hydroxyrisperidone combined, and no change for 9-hydroxyrisperidone were observed. This interaction is unlikely to be of clinical significance. There was no clinically relevant effect of oral RISPERDAL[®] on the pharmacokinetics of topiramate.

7.11 Drugs That Inhibit CYP 2D6 and Other CYP Isozymes

Risperidone is metabolized to 9-hydroxyrisperidone by CYP 2D6, an enzyme that is polymorphic in the population and that can be inhibited by a variety of psychotropic and other drugs [see *Clinical Pharmacology* (12.3)]. Drug interactions that reduce the metabolism of risperidone to 9-hydroxyrisperidone would increase the plasma concentrations of risperidone and lower the concentrations of 9-hydroxyrisperidone. Analysis of clinical studies involving a modest number of poor metabolizers (n≅70 patients) does not suggest that poor and extensive metabolizers have different rates of adverse effects. No comparison of effectiveness in the two groups has been made.

In vitro studies showed that drugs metabolized by other CYP isozymes, including 1A1, 1A2, 2C9, 2C19, and 3A4, are only weak inhibitors of risperidone metabolism.

Fluoxetine and Paroxetine

Fluoxetine (20 mg once daily) and paroxetine (20 mg once daily), CYP 2D6 inhibitors, have been shown to increase the plasma concentration of risperidone 2.5-2.8 fold and 3.9 fold respectively. Fluoxetine did not affect the plasma concentration of 9-hydroxyrisperidone. Paroxetine lowered the concentration of 9-hydroxyrisperidone by about 10%. When either concomitant fluoxetine or paroxetine is initiated or discontinued, the physician should re-evaluate the dose of RISPERDAL[®] CONSTA[®]. When initiation of fluoxetine or paroxetine is considered, patients may be placed on a lower dose of RISPERDAL[®] CONSTA[®] between 2 to 4 weeks before the planned start of fluoxetine or paroxetine therapy to adjust for the expected increase in plasma concentrations of risperidone. When fluoxetine or paroxetine is initiated in patients receiving the recommended dose of 25 mg RISPERDAL[®] CONSTA[®], it is recommended to continue treatment with the 25 mg dose unless clinical judgment necessitates lowering the RISPERDAL[®] CONSTA[®] dose to 12.5 mg or necessitates interruption of RISPERDAL[®] CONSTA[®] treatment. When RISPERDAL[®] CONSTA[®] is initiated in patients already receiving fluoxetine or paroxetine, a starting dose of 12.5 mg can be considered. The efficacy of the 12.5 mg dose has not been investigated in clinical trials. [see also *DOSAGE AND ADMINISTRATION* (2.5)]. The effects of discontinuation of concomitant fluoxetine or paroxetine therapy on the pharmacokinetics of risperidone and 9-hydroxyrisperidone have not been studied.

Erythromycin

There were no significant interactions between oral RISPERDAL[®] and erythromycin.

7.12 Carbamazepine and Other CYP 3A4 Enzyme Inducers

Carbamazepine co-administration with oral RISPERDAL[®] decreased the steady-state plasma concentrations of risperidone and 9-hydroxyrisperidone by about 50%. Plasma concentrations of carbamazepine did not appear to be affected. Co-administration of other known CYP 3A4 enzyme inducers (e.g., phenytoin, rifampin, and phenobarbital) with risperidone may cause similar decreases in the combined plasma concentrations of risperidone and 9-hydroxyrisperidone, which could lead to decreased efficacy of RISPERDAL[®] CONSTA[®] treatment. At the initiation of therapy with carbamazepine or other known hepatic enzyme inducers, patients should be closely monitored during

the first 4 - 8 weeks, since the dose of RISPERDAL® CONSTA® may need to be adjusted. A dose increase, or additional oral RISPERDAL®, may need to be considered. On discontinuation of carbamazepine or other CYP 3A4 hepatic enzyme inducers, the dosage of RISPERDAL® CONSTA® should be re-evaluated and, if necessary, decreased. Patients may be placed on a lower dose of RISPERDAL® CONSTA® between 2 to 4 weeks before the planned discontinuation of carbamazepine or other CYP 3A4 enzyme inducers to adjust for the expected increase in plasma concentrations of risperidone plus 9-hydroxyrisperidone. For patients treated with the recommended dose of 25 mg RISPERDAL® CONSTA® and discontinuing from carbamazepine or other CYP 3A4 enzyme inducers, it is recommended to continue treatment with the 25 mg dose unless clinical judgment necessitates lowering the RISPERDAL® CONSTA® dose to 12.5 mg or necessitates interruption of RISPERDAL® CONSTA® treatment. The efficacy of the 12.5 mg dose has not been investigated in clinical trials. [see also *DOSAGE AND ADMINISTRATION (2.5)*]

7.13 Drugs Metabolized by CYP 2D6

In vitro studies indicate that risperidone is a relatively weak inhibitor of CYP 2D6. Therefore, RISPERDAL® CONSTA® is not expected to substantially inhibit the clearance of drugs that are metabolized by this enzymatic pathway. In drug interaction studies, oral RISPERDAL® did not significantly affect the pharmacokinetics of donepezil and galantamine, which are metabolized by CYP 2D6.

8 USE IN SPECIFIC POPULATIONS

8.1 Pregnancy

Pregnancy Category C.

The teratogenic potential of oral risperidone was studied in three embryofetal development studies in Sprague-Dawley and Wistar rats (0.63-10 mg/kg or 0.4 to 6 times the oral maximum recommended human dose [MRHD] on a mg/m² basis) and in one embryofetal development study in New Zealand rabbits (0.31-5 mg/kg or 0.4 to 6 times the oral MRHD on a mg/m² basis). The incidence of malformations was not increased compared to control in offspring of rats or rabbits given 0.4 to 6 times the oral MRHD on a mg/m² basis. In three reproductive studies in rats (two peri/post-natal development studies and a multigenerational study), there was an increase in pup deaths during the first 4 days of lactation at doses of 0.16 5 mg/kg or 0.1 to 3 times the oral MRHD on a mg/m² basis. It is not known whether these deaths were due to a direct effect on the fetuses or pups or to effects on the dams.

There was no no-effect dose for increased rat pup mortality. In one peri/post-natal development study, there was an increase in stillborn rat pups at a dose of 2.5 mg/kg or 1.5 times the oral MRHD on a mg/m² basis. In a cross-fostering study in Wistar rats, toxic effects on the fetus or pups, as evidenced by a decrease in the number of live pups and an increase in the number of dead pups at birth (Day 0), and a decrease in birth weight in pups of drug-treated dams were observed. In addition, there was an increase in deaths by Day 1 among pups of drug-treated dams, regardless of whether or not the pups were cross-fostered. Risperidone also appeared to impair maternal behavior in that pup body weight gain and survival (from Days 1 to 4 of lactation) were reduced in pups born to control but reared by drug-treated dams. These effects were all noted at the one dose of risperidone tested, i.e., 5 mg/kg or 3 times the oral MRHD on a mg/m² basis.

No studies were conducted with RISPERDAL® CONSTA®.

Placental transfer of risperidone occurs in rat pups. There are no adequate and well controlled studies in pregnant women. However, there was one report of a case of agenesis of the corpus callosum in an infant exposed to risperidone *in utero*. The causal relationship to oral RISPERDAL[®] therapy is unknown.

Non_Teratogenic Effects

Neonates exposed to antipsychotic drugs (including RISPERDAL[®]) during the third trimester of pregnancy are at risk for extrapyramidal and/or withdrawal symptoms following delivery. There have been reports of agitation, hypertonia, hypotonia, tremor, somnolence, respiratory distress, and feeding disorder in these neonates. These complications have varied in severity; while in some cases symptoms have been self-limited, in other cases neonates have required intensive care unit support and prolonged hospitalization.

RISPERDAL[®] CONSTA[®] should be used during pregnancy only if the potential benefit justifies the potential risk to the fetus.

8.2 Labor and Delivery

The effect of RISPERDAL[®] CONSTA[®] on labor and delivery in humans is unknown.

8.3 Nursing Mothers

Risperidone and 9-hydroxyrisperidone are also excreted in human breast milk. Therefore, women should not breast-feed during treatment with RISPERDAL[®] CONSTA[®] and for at least 12 weeks after the last injection.

8.4 Pediatric Use

RISPERDAL[®] CONSTA[®] has not been studied in children younger than 18 years old.

However, juvenile animal toxicology studies have been conducted with oral risperidone.

Juvenile dogs were treated for 40 weeks with oral risperidone doses of 0.31, 1.25, or 5 mg/kg/day. Decreased bone length and density were seen, with a no-effect dose of 0.31 mg/kg/day. This dose produced plasma levels (AUC) of risperidone plus its active metabolite paliperidone (9-hydroxyrisperidone) which were similar to those in children and adolescents receiving the maximum recommended human dose (MRHD) of 6mg/day. In addition, a delay in sexual maturation was seen at all doses in both males and females. The above effects showed little or no reversibility in females after a 12 week drug-free recovery period.

In a study in which juvenile rats were treated with oral risperidone from days 12 to 50 of age, a reversible impairment of performance in a test of learning and memory was seen, in females only, with a no-effect dose of 0.63 mg/kg/day. This dose produced plasma levels (AUC) of risperidone plus paliperidone about half those observed in humans at the MRHD. No other consistent effects on neurobehavioral or reproductive development were seen up to the highest testable dose (1.25 mg/kg/day). Thi dose produced plasma levels (AUC) of risperidone plus paliperidone which were about two thirds of those observed in humans at the MRHD

The long-term effects of risperidone on growth and sexual maturation have not been fully evaluated in children and adolescents.

8.5 Geriatric Use

In an open-label study, 57 clinically stable, elderly patients (≥ 65 years old) with schizophrenia or schizoaffective disorder received RISPERDAL[®] CONSTA[®] every 2 weeks for up to 12 months. In general, no differences in the tolerability of RISPERDAL[®] CONSTA[®] were observed between otherwise healthy elderly and nonelderly patients. Therefore, dosing recommendations for otherwise healthy elderly patients are the same as for nonelderly patients. Because elderly patients exhibit a greater tendency to orthostatic hypotension than nonelderly patients, elderly patients should be instructed in nonpharmacologic interventions that help to reduce the occurrence of orthostatic hypotension (e.g., sitting on the edge of the bed for several minutes before attempting to stand in the morning and slowly rising from a seated position). In addition, monitoring of orthostatic vital signs should be considered in elderly patients for whom orthostatic hypotension is of concern [see *Warnings and Precautions* (5.7)].

Concomitant use with Furosemide in Elderly Patients with Dementia-Related Psychosis

In two of four placebo-controlled trials in elderly patients with dementia-related psychosis, a higher incidence of mortality was observed in patients treated with furosemide plus oral risperidone when compared to patients treated with oral risperidone alone or with oral placebo plus furosemide. No pathological mechanism has been identified to explain this finding, and no consistent pattern for cause of death was observed. An increase of mortality in elderly patients with dementia-related psychosis was seen with the use of oral risperidone regardless of concomitant use with furosemide. RISPERDAL[®] CONSTA[®] is not approved for the treatment of patients with dementia-related psychosis. [see *Boxed Warning and Warnings and Precautions* (5.1)]

9 DRUG ABUSE AND DEPENDENCE

9.1 Controlled Substance

RISPERDAL[®] CONSTA[®] (risperidone) is not a controlled substance.

9.2 Abuse

RISPERDAL[®] CONSTA[®] has not been systematically studied in animals or humans for its potential for abuse. Because RISPERDAL[®] CONSTA[®] is to be administered by health care professionals, the potential for misuse or abuse by patients is low.

9.3 Dependence

RISPERDAL[®] CONSTA[®] has not been systematically studied in animals or humans for its potential for tolerance or physical dependence.

10 OVERDOSAGE

10.1 Human Experience

No cases of overdose were reported in premarketing studies with RISPERDAL[®] CONSTA[®]. Because RISPERDAL[®] CONSTA[®] is to be administered by health care professionals, the potential for overdose by patients is low.

In premarketing experience with oral RISPERDAL[®], there were eight reports of acute RISPERDAL[®] overdose, with estimated doses ranging from 20 to 300 mg and no fatalities. In general, reported

signs and symptoms were those resulting from an exaggeration of the drug's known pharmacological effects, i.e., drowsiness and sedation, tachycardia and hypotension, and extrapyramidal symptoms. One case, involving an estimated overdose of 240 mg, was associated with hyponatremia, hypokalemia, prolonged QT, and widened QRS. Another case, involving an estimated overdose of 36 mg, was associated with a seizure.

Postmarketing experience with oral RISPERDAL[®] includes reports of acute overdose, with estimated doses of up to 360 mg. In general, the most frequently reported signs and symptoms are those resulting from an exaggeration of the drug's known pharmacological effects, i.e., drowsiness, sedation, tachycardia, hypotension, and extrapyramidal symptoms. Other adverse reactions reported since market introduction related to oral RISPERDAL[®] overdose include prolonged QT interval and convulsions. Torsade de pointes has been reported in association with combined overdose of oral RISPERDAL[®] and paroxetine.

10.2 Management of Overdosage

In case of acute overdosage, establish and maintain an airway and ensure adequate oxygenation and ventilation. Cardiovascular monitoring should commence immediately and should include continuous electrocardiographic monitoring to detect possible arrhythmias. If antiarrhythmic therapy is administered, disopyramide, procainamide, and quinidine carry a theoretical hazard of QT prolonging effects that might be additive to those of risperidone. Similarly, it is reasonable to expect that the alpha-blocking properties of bretylium might be additive to those of risperidone, resulting in problematic hypotension.

There is no specific antidote to risperidone. Therefore, appropriate supportive measures should be instituted. The possibility of multiple drug involvement should be considered. Hypotension and circulatory collapse should be treated with appropriate measures, such as intravenous fluids and/or sympathomimetic agents (epinephrine and dopamine should not be used, since beta stimulation may worsen hypotension in the setting of risperidone-induced alpha blockade). In cases of severe extrapyramidal symptoms, anticholinergic medication should be administered. Close medical supervision and monitoring should continue until the patient recovers.

11 DESCRIPTION

Risperidone is a psychotropic agent belonging to the chemical class of benzisoxazole derivatives. The chemical designation is 3-[2-[4-(6-fluoro-1,2-benzisoxazol-3-yl)-1-piperidinyl]ethyl]-6,7,8,9-tetrahydro-2-methyl-4H-pyrido[1,2-a]pyrimidin-4-one. Its molecular formula is C₂₃H₂₇FN₄O₂ and its molecular weight is 410.49. The structural formula is:

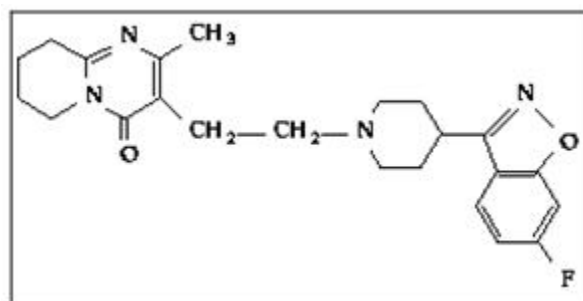

Risperidone is practically insoluble in water, freely soluble in methylene chloride, and soluble in methanol and 0.1 N HCl.

RISPERDAL[®] CONSTA[®] (risperidone) Long-Acting Injection is a combination of extended-release microspheres for injection and diluent for parenteral use.

The extended-release microspheres formulation is a white to off-white, free-flowing powder that is available in dosage strengths of 25 mg, 37.5 mg, or 50 mg risperidone per vial. Risperidone is micro encapsulated in 7525 polylactide-co-glycolide (PLG) at a concentration of 381 mg risperidone per gram of microspheres.

The diluent for parenteral use is a clear, colorless solution. Composition of the diluent includes polysorbate 20, sodium carboxymethyl cellulose, disodium hydrogen phosphate dihydrate, citric acid anhydrous, sodium chloride, sodium hydroxide, and water for injection. The microspheres are suspended in the diluent prior to injection.

RISPERDAL[®] CONSTA[®] is provided as a dose pack, consisting of a vial containing the microspheres, a pre-filled syringe containing the diluent, a SmartSite[®] Needle Free Vial Access Device, and two Needle-Pro[®] safety needles (a 21 G UTW 1-inch needle with needle protection device for deltoid administration and a 20 G TW 2-inch needle with needle protection device for gluteal administration).

12 CLINICAL PHARMACOLOGY

12.1 Mechanism of Action

The mechanism of action of RISPERDAL[®] CONSTA[®], as with other drugs used to treat schizophrenia, is unknown. However, it has been proposed that the drug's therapeutic activity in schizophrenia is mediated through a combination of dopamine Type 2 (D₂) and serotonin Type 2 (5HT₂) receptor antagonism.

RISPERDAL[®] is a selective monoaminergic antagonist with high affinity (K_i of 0.12 to 7.3 nM) for the serotonin Type 2 (5HT₂), dopamine Type 2 (D₂), α₁ and α₂ adrenergic, and H₁ histaminergic receptors. RISPERDAL[®] acts as an antagonist at other receptors, but with lower potency. RISPERDAL[®] has low to moderate affinity (K_i of 47 to 253 nM) for the serotonin 5HT_{1C}, 5HT_{1D}, and 5HT_{1A} receptors, weak affinity (K_i of 620 to 800 nM) for the dopamine D₁ and haloperidol-sensitive sigma site, and no affinity (when tested at concentrations >10⁻⁵ M) for cholinergic muscarinic or β₁ and β₂ adrenergic receptors.

12.2 Pharmacodynamics

The clinical effect from RISPERDAL[®] CONSTA[®] results from the combined concentrations of risperidone and its major metabolite, 9-hydroxyrisperidone [see *Clinical Pharmacology (12.3)*]. Antagonism at receptors other than D₂ and 5HT₂ [see *Clinical Pharmacology (12.1)*] may explain some of the other effects of RISPERDAL[®] CONSTA[®].

12.3 Pharmacokinetics

Absorption

After a single intramuscular (gluteal) injection of RISPERDAL[®] CONSTA[®], there is a small initial release of the drug (< 1% of the dose), followed by a lag time of 3 weeks. The main release of the drug starts from 3 weeks onward, is maintained from 4 to 6 weeks, and subsides by 7 weeks following the intramuscular (IM) injection. Therefore, oral antipsychotic supplementation should be given during the

first 3 weeks of treatment with RISPERDAL[®] CONSTA[®] to maintain therapeutic levels until the main release of risperidone from the injection site has begun [see *Dosage and Administration (2)*]. Following single doses of RISPERDAL[®] CONSTA[®], the pharmacokinetics of risperidone, 9-hydroxyrisperidone (the major metabolite), and risperidone plus 9-hydroxyrisperidone were linear in the dosing range of 12.5 mg to 50 mg.

The combination of the release profile and the dosage regimen (IM injections every 2 weeks) of RISPERDAL[®] CONSTA[®] results in sustained therapeutic concentrations. Steady-state plasma concentrations are reached after 4 injections and are maintained for 4 to 6 weeks after the last injection. Following multiple doses of 25 mg and 50 mg RISPERDAL[®] CONSTA[®], plasma concentrations of risperidone, 9-hydroxyrisperidone, and risperidone plus 9-hydroxyrisperidone were linear.

Deltoid and gluteal intramuscular injections at the same doses are bioequivalent and, therefore, interchangeable.

Distribution

Once absorbed, risperidone is rapidly distributed. The volume of distribution is 1 - 2 L/kg. In plasma, risperidone is bound to albumin and α 1-acid glycoprotein. The plasma protein binding of risperidone is approximately 90%, and that of its major metabolite, 9-hydroxyrisperidone, is 77%. Neither risperidone nor 9-hydroxyrisperidone displaces each other from plasma binding sites. High therapeutic concentrations of sulfamethazine (100 mcg/mL), warfarin (10 mcg/mL), and carbamazepine (10 mcg/mL) caused only a slight increase in the free fraction of risperidone at 10 ng/mL and of 9-hydroxyrisperidone at 50 ng/mL, changes of unknown clinical significance.

Metabolism and Drug Interactions

Risperidone is extensively metabolized in the liver. The main metabolic pathway is through hydroxylation of risperidone to 9-hydroxyrisperidone by the enzyme, CYP 2D6. A minor metabolic pathway is through N-dealkylation. The main metabolite, 9-hydroxyrisperidone, has similar pharmacological activity as risperidone. Consequently, the clinical effect of the drug results from the combined concentrations of risperidone plus 9-hydroxyrisperidone.

CYP 2D6, also called debrisoquin hydroxylase, is the enzyme responsible for metabolism of many neuroleptics, antidepressants, antiarrhythmics, and other drugs. CYP 2D6 is subject to genetic polymorphism (about 6%-8% of Caucasians, and a very low percentage of Asians, have little or no activity and are "poor metabolizers") and to inhibition by a variety of substrates and some non-substrates, notably quinidine. Extensive CYP 2D6 metabolizers convert risperidone rapidly into 9-hydroxyrisperidone, whereas poor CYP 2D6 metabolizers convert it much more slowly. Although extensive metabolizers have lower risperidone and higher 9-hydroxyrisperidone concentrations than poor metabolizers, the pharmacokinetics of risperidone and 9-hydroxyrisperidone combined, after single and multiple doses, are similar in extensive and poor metabolizers.

The interactions of RISPERDAL[®] CONSTA[®] with coadministration of other drugs have not been systematically evaluated in human subjects. Drug interactions are based primarily on experience with oral RISPERDAL[®]. Risperidone could be subject to two kinds of drug drug interactions. First, inhibitors of CYP 2D6 interfere with conversion of risperidone to 9-hydroxyrisperidone [see *Drug Interactions (7.11)*]. This occurs with quinidine, giving essentially all recipients a risperidone pharmacokinetic profile typical of poor metabolizers. The therapeutic benefits and adverse effects of RISPERDAL[®] in patients receiving quinidine have not been evaluated, but observations in a modest number ($n \geq 70$) of poor metabolizers given oral RISPERDAL[®] do not suggest important differences between poor and extensive

metabolizers. Second, co-administration of carbamazepine and other known enzyme inducers (e.g., phenytoin, rifampin, and phenobarbital) with oral RISPERDAL[®] cause a decrease in the combined plasma concentrations of risperidone and 9-hydroxyrisperidone [see *Drug Interactions (7.12)*]. It would also be possible for risperidone to interfere with metabolism of other drugs metabolized by CYP 2D6. Relatively weak binding of risperidone to the enzyme suggests this is unlikely [see *Drug Interactions (7.11)*].

Excretion

Risperidone and its metabolites are eliminated via the urine and, to a much lesser extent, via the feces. As illustrated by a mass balance study of a single 1 mg oral dose of ¹⁴C risperidone administered as solution to three healthy male volunteers, total recovery of radioactivity at 1 week was 84%, including 70% in the urine and 14% in the feces.

The apparent half-life of risperidone plus 9-hydroxyrisperidone following RISPERDAL[®] CONSTA[®] administration is 3 to 6 days, and is associated with a monoexponential decline in plasma concentrations. This half-life of 3-6 days is related to the erosion of the microspheres and subsequent absorption of risperidone. The clearance of risperidone and risperidone plus 9-hydroxyrisperidone was 13.7 L/h and 5.0 L/h in extensive CYP 2D6 metabolizers, and 3.3 L/h and 3.2 L/h in poor CYP 2D6 metabolizers, respectively. No accumulation of risperidone was observed during long-term use (up to 12 months) in patients treated every 2 weeks with 25 mg or 50 mg RISPERDAL[®] CONSTA[®]. The elimination phase is complete approximately 7 to 8 weeks after the last injection.

Renal Impairment

In patients with moderate to severe renal disease treated with oral RISPERDAL[®], clearance of the sum of risperidone and its active metabolite decreased by 60% compared with young healthy subjects. Although patients with renal impairment were not studied with RISPERDAL[®] CONSTA[®], it is recommended that patients with renal impairment be carefully titrated on oral RISPERDAL[®] before treatment with RISPERDAL[®] CONSTA[®] is initiated at a dose of 25 mg. A lower initial dose of 12.5 mg may be appropriate when clinical factors warrant dose adjustment, such as in patients with renal impairment [see *Dosage and Administration (2.4)*].

Hepatic Impairment

While the pharmacokinetics of oral RISPERDAL[®] in subjects with liver disease were comparable to those in young healthy subjects, the mean free fraction of risperidone in plasma was increased by about 35% because of the diminished concentration of both albumin and α 1-acid glycoprotein. Although patients with hepatic impairment were not studied with RISPERDAL[®] CONSTA[®], it is recommended that patients with hepatic impairment be carefully titrated on oral RISPERDAL[®] before treatment with RISPERDAL[®] CONSTA[®] is initiated at a dose of 25 mg. A lower initial dose of 12.5 mg may be appropriate when clinical factors warrant dose adjustment, such as in patients with hepatic impairment [see *Dosage and Administration (2.4)*].

Elderly

In an open label trial, steady state concentrations of risperidone plus 9-hydroxyrisperidone in otherwise healthy elderly patients (≥ 65 years old) treated with RISPERDAL[®] CONSTA[®] for up to 12 months fell within the range of values observed in otherwise healthy nonelderly patients. Dosing recommendations

are the same for otherwise healthy elderly patients and nonelderly patients [see *Dosage and Administration* (2)].

Race and Gender Effects

No specific pharmacokinetic study was conducted to investigate race and gender effects, but a population pharmacokinetic analysis did not identify important differences in the disposition of risperidone due to gender (whether or not corrected for body weight) or race.

13 NONCLINICAL TOXICOLOGY

13.1 Carcinogenesis, Mutagenesis, Impairment of Fertility

Carcinogenesis - Oral

Carcinogenicity studies were conducted in Swiss albino mice and Wistar rats. Risperidone was administered in the diet at doses of 0.63, 2.5, and 10 mg/kg for 18 months to mice and for 25 months to rats. These doses are equivalent to 2.4, 9.4, and 37.5 times the oral maximum recommended human dose (MRHD) for schizophrenia (16 mg/day) on a mg/kg basis, or 0.2, 0.75, and 3 times the oral MRHD (mice) or 0.4, 1.5, and 6 times the oral MRHD (rats) on a mg/m² basis. A maximum tolerated dose was not achieved in male mice. There was a significant increase in pituitary gland adenomas in female mice at doses 0.75 and 3 times the oral MRHD on a mg/m² basis. There was a significant increase in endocrine pancreatic adenomas in male rats at doses 1.5 and 6 times the oral MRHD on a mg/m² basis. Mammary gland adenocarcinomas were significantly increased in female mice at all doses tested (0.2, 0.75, and 3 times the oral MRHD on a mg/m² basis), in female rats at all doses tested (0.4, 1.5, and 6 times the oral MRHD on a mg/m² basis), and in male rats at a dose 6 times the oral MRHD on a mg/m² basis.

Carcinogenesis - Intramuscular

RISPERDAL[®] CONSTA[®] was evaluated in a 24 month carcinogenicity study in which SPF Wistar rats were treated every 2 weeks with intramuscular (IM) injections of either 5 mg/kg or 40 mg/kg of risperidone. These doses are 1 and 8 times the MRHD (50 mg) on a mg/m² basis. A control group received injections of 0.9% NaCl, and a vehicle control group was injected with placebo microspheres. There was a significant increase in pituitary gland adenomas, endocrine pancreas adenomas, and adrenomedullary pheochromocytomas at 8 times the IM MRHD on a mg/m² basis. The incidence of mammary gland adenocarcinomas was significantly increased in female rats at both doses (1 and 8 times the IM MRHD on a mg/m² basis). A significant increase in renal tubular tumors (adenoma, adenocarcinomas) was observed in male rats at 8 times the IM MRHD on a mg/m² basis. Plasma exposures (AUC) in rats were 0.3 and 2 times (at 5 and 40 mg/kg, respectively) the expected plasma exposure (AUC) at the IM MRHD.

Dopamine D₂ receptor antagonists have been shown to chronically elevate prolactin levels in rodents. Serum prolactin levels were not measured during the carcinogenicity studies of oral risperidone; however, measurements taken during subchronic toxicity studies showed that oral risperidone elevated serum prolactin levels 5- to 6-fold in mice and rats at the same doses used in the oral carcinogenicity studies. Serum prolactin levels increased in a dose dependent manner up to 6- and 1.5-fold in male and female rats, respectively, at the end of the 24-month treatment with RISPERDAL[®] CONSTA[®] every 2 weeks. Increases in the incidence of pituitary gland, endocrine pancreas, and mammary gland neoplasms have been found in rodents after chronic administration of other antipsychotic drugs and may be prolactin-mediated.

The relevance for human risk of the findings of prolactin mediated endocrine tumors in rodents is unknown [see *Warnings and Precautions (5.6)*].

Mutagenesis

No evidence of mutagenic potential for oral risperidone was found in the *in vitro* Ames reverse mutation test, *in vitro* mouse lymphoma assay, *in vitro* rat hepatocyte DNA repair assay, *in vivo* oral micronucleus test in mice, the sex linked recessive lethal test in *Drosophila*, or the *in vitro* chromosomal aberration test in human lymphocytes or in Chinese hamster cells.

In addition, no evidence of mutagenic potential was found in the *in vitro* Ames reverse mutation test for RISPERDAL[®] CONSTA[®].

Impairment of Fertility

Oral risperidone (0.16 to 5 mg/kg) was shown to impair mating, but not fertility, in Wistar rats in three reproductive studies (two mating and fertility studies and a multigenerational study) at doses 0.1 to 3 times the oral maximum recommended human dose (MRHD) (16 mg/day) on a mg/m² basis. The effect appeared to be in females, since impaired mating behavior was not noted in the mating and fertility study in which males only were treated. In a subchronic study in Beagle dogs in which oral risperidone was administered at doses of 0.31 to 5 mg/kg, sperm motility and concentration were decreased at doses 0.6 to 10 times the oral MRHD on a mg/m² basis. Dose related decreases were also noted in serum testosterone at the same doses. Serum testosterone and sperm values partially recovered, but remained decreased after treatment was discontinued. No no effect doses were noted in either rat or dog.

No mating and fertility studies were conducted with RISPERDAL[®] CONSTA[®].

14 CLINICAL STUDIES

14.1 Schizophrenia

The effectiveness of RISPERDAL[®] CONSTA[®] in the treatment of schizophrenia was established, in part, on the basis of extrapolation from the established effectiveness of the oral formulation of risperidone. In addition, the effectiveness of RISPERDAL[®] CONSTA[®] in the treatment of schizophrenia was established in a 12-week, placebo-controlled trial in adult psychotic inpatients and outpatients who met the DSM IV criteria for schizophrenia.

Efficacy data were obtained from 400 patients with schizophrenia who were randomized to receive injections of 25 mg, 50 mg, or 75 mg RISPERDAL[®] CONSTA[®] or placebo every 2 weeks. During a 1 week run in period, patients were discontinued from other antipsychotics and were titrated to a dose of 4 mg oral RISPERDAL[®]. Patients who received RISPERDAL[®] CONSTA[®] were given doses of oral RISPERDAL[®] (2 mg for patients in the 25-mg group, 4 mg for patients in the 50 mg group, and 6 mg for patients in the 75 mg group) for the 3 weeks after the first injection to provide therapeutic plasma concentrations until the main release phase of risperidone from the injection site had begun. Patients who received placebo injections were given placebo tablets.

Efficacy was evaluated using the Positive and Negative Syndrome Scale (PANSS), a validated, multi-item inventory, composed of five subscales to evaluate positive symptoms, negative symptoms, disorganized thoughts, uncontrolled hostility/excitement, and anxiety/depression.

The primary efficacy variable in this trial was change from baseline to endpoint in the total PANSS score. The mean total PANSS score at baseline for schizophrenic patients in this study was 81.5.

Total PANSS scores showed significant improvement in the change from baseline to endpoint in schizophrenic patients treated with each dose of RISPERDAL[®] CONSTA[®] (25 mg, 50 mg, or 75 mg) compared with patients treated with placebo. While there were no statistically significant differences between the treatment effects for the three dose groups, the effect size for the 75 mg dose group was actually numerically less than that observed for the 50 mg dose group.

Subgroup analyses did not indicate any differences in treatment outcome as a function of age, race, or gender.

14.2 Bipolar Disorder - Monotherapy

The effectiveness of RISPERDAL[®] CONSTA[®] for the maintenance treatment of Bipolar I Disorder was established in a multicenter, double-blind, placebo-controlled study of adult patients who met DSM-IV criteria for Bipolar Disorder Type I, who were stable on medications or experiencing an acute manic or mixed episode.

A total of 501 patients were treated during a 26-week open-label period with RISPERDAL[®] CONSTA[®] (starting dose of 25 mg, and titrated, if deemed clinically desirable, to 37.5 mg or 50 mg; in patients not tolerating the 25 mg dose, the dose could be reduced to 12.5 mg). In the open-label phase, 303 (60%) patients were judged to be stable and were randomized to double-blind treatment with either the same dose of RISPERDAL[®] CONSTA[®] or placebo and monitored for relapse. The primary endpoint was time to relapse to any mood episode (depression, mania, hypomania, or mixed).

Time to relapse was delayed in patients receiving RISPERDAL[®] CONSTA[®] monotherapy as compared to placebo. The majority of relapses were due to manic rather than depressive symptoms. Based on their bipolar disorder history, subjects entering this study had had, on average, more manic episodes than depressive episodes.

14.3 Bipolar Disorder - Adjunctive Therapy

The effectiveness of RISPERDAL[®] CONSTA[®] as an adjunct to treatment with lithium or valproate for the maintenance treatment of Bipolar Disorder was established in a multi-center, randomized, double-blind, placebo-controlled study of adult patients who met DSM-IV criteria for Bipolar Disorder Type I and who experienced at least 4 episodes of mood disorder requiring psychiatric/clinical intervention in the previous 12 months, including at least 2 episodes in the 6 months prior to the start of the study.

A total of 240 patients were treated during a 16-week open-label period with RISPERDAL[®] CONSTA[®] (starting dose of 25 mg, and titrated, if deemed clinically desirable, to 37.5 mg or 50 mg), as adjunctive therapy in addition to continuing their treatment as usual for their bipolar disorder, which consisted of mood stabilizers (primarily lithium and valproate), antidepressants, and/or anxiolytics. All oral antipsychotics were discontinued after the first three weeks of the initial RISPERDAL[®] CONSTA[®] injection. In the open-label phase, 124 (51.7%) were judged to be stable for at least the last 4 weeks and were randomized to double-blind treatment with either the same dose of RISPERDAL[®] CONSTA[®] or placebo in addition to continuing their treatment as usual and monitored for relapse during a 52-week period. The primary endpoint was time to relapse to any new mood episode (depression, mania, hypomania, or mixed).

Time to relapse was delayed in patients receiving adjunctive therapy with RISPERDAL® CONSTA® as compared to placebo. The relapse types were about half depressive and half manic or mixed episodes.

16 HOW SUPPLIED/STORAGE AND HANDLING

RISPERDAL® CONSTA® (risperidone) is available in dosage strengths of 25 mg, 37.5 mg, or 50 mg risperidone. It is provided as a dose pack, consisting of a vial containing the risperidone microspheres, a pre filled syringe containing 2 mL of diluent for RISPERDAL® CONSTA®, a SmartSite® Needle-Free Vial Access Device, and two Needle-Pro® safety needles for intramuscular injection (a 21 G UTW 1-inch needle with needle protection device for deltoid administration and a 20 G TW 2-inch needle with needle protection device for gluteal administration).

25-mg vial/kit: 78 mg (equivalent to 25 mg of risperidone) of a white to off-white powder provided in a vial with a pink flip-off cap.

37.5-mg vial/kit: 116 mg (equivalent to 37.5 mg of risperidone) of a white to off-white powder provided in a vial with a green flip-off cap.

50-mg vial/kit: 152 mg (equivalent to 50 mg of risperidone) of a white to off-white powder provided in a vial with a blue flip-off cap.

Storage and Handling

The entire dose pack should be stored in the refrigerator (2°- 8°C) and protected from light.

If refrigeration is unavailable, RISPERDAL® CONSTA® can be stored at temperatures not exceeding 25°C for no more than 7 days prior to administration. Do not expose unrefrigerated product to temperatures above 25°C.

After reconstitution: Chemical and physical in-use stability has been demonstrated for 24 hours at 25°C. From a microbiological point of view, the product should be used immediately. If not used immediately, in-use storage times and conditions prior to use are the responsibility of the user and should normally not be longer than 6 hours at 25°C, unless reconstitution has taken place in controlled and validated aseptic conditions.

Keep out of reach of children.

17 PATIENT COUNSELING INFORMATION

Physicians are advised to discuss the following issues with patients for whom they prescribe RISPERDAL® CONSTA®.

17.1 Orthostatic Hypotension

Patients should be advised of the risk of orthostatic hypotension and instructed in nonpharmacologic interventions that help to reduce the occurrence of orthostatic hypotension (e.g., sitting on the edge of the bed for several minutes before attempting to stand in the morning and slowly rising from a seated position) [see *Warnings and Precautions (5.7)*].

17.2 Interference with Cognitive and Motor Performance

Because RISPERDAL® CONSTA® has the potential to impair judgment, thinking, or motor skills, patients should be cautioned about operating hazardous machinery, including automobiles, until they are reasonably certain that treatment with RISPERDAL® CONSTA® does not affect them adversely [see *Warnings and Precautions (5.9)*].

17.3 Pregnancy

Patients should be advised to notify their physician if they become pregnant or intend to become pregnant during therapy and for at least 12 weeks after the last injection of RISPERDAL® CONSTA® [see *Use in Specific Populations (8.1)*].

17.4 Nursing

Patients should be advised not to breast-feed an infant during treatment and for at least 12 weeks after the last injection of RISPERDAL® CONSTA® [see *Use in Specific Populations (8.3)*].

17.5 Concomitant Medication

Patients should be advised to inform their physicians if they are taking, or plan to take, any prescription or over-the-counter drugs, since there is a potential for interactions [see *Drug Interactions (7)*].

17.6 Alcohol

Patients should be advised to avoid alcohol during treatment with RISPERDAL® CONSTA® [see *Drug Interactions (7.1)*].

Manufacturer : Cilag AG, Schaffhausen, Switzerland

Registration Holder: J-C Health Care Ltd., Kibbutz Shefayim 6099000
